

**DualTech®**

**Design &  
Installation Guide**

*Corrosion Resistant Fluid and  
Air Handling Systems.*

**SIMTECH**

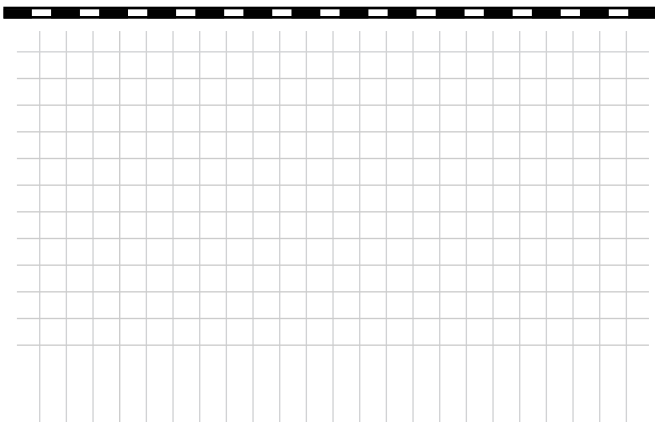

# Simtech Stress Relieved Piping Systems

## TABLE OF CONTENTS

### SECTION 1

SYSTEM COMPOSITION .....	3
Pipe & Fitting Liners .....	4
Resin System .....	4

### SECTION 2

PIPE PHYSICAL PROPERTIES .....	5
Typical Pipe Properties .....	5
Properties of Contact Molded Laminate w/Hetron 922 .....	5
System Pressure Rating .....	6
Flow Characteristics .....	6
Pressure Loss for Dual Tech PP Pipe .....	7
Pressure Loss for Dual Tech VF Pipe .....	8
Pressure Drop for Fittings .....	9
Water Hammer .....	9
Supporting Dual Tech .....	10
Hangers and Supports .....	11
Hanger with Support Saddle Detail .....	12
Typical Guide Arrangement .....	12
Typical Valve Support and Anchor .....	12
Anchors and Guides .....	12
Thermal Expansion and Contraction .....	12
Thermal End loads Due to Temperature Change .....	13
Axial End load Due to 100 psi Internal Pressure .....	13
Flexible Installation .....	14
Anchor Location .....	14
Required Anchor Offset .....	15
Expansion Loops .....	16
Typical Loop Arrangement .....	16
Expansion Loop Design .....	17
Guide Spacing at Loop or Expansion Joint .....	17
Expansion Joints .....	17
Restrained Installation .....	18
Guide Spacing .....	18
Allowable Tensile Load .....	18

### SECTION 3

JOINING PROCEDURE .....	19
Dual Tech Tools, Equipment and Supplies .....	20
Procedures for Welding .....	21-22
Pipe Alignment .....	22
Welding Charts .....	23
Flanged Dual Tech .....	24
Quick Wrap Kits .....	25

### SECTION 4

DIMENSIONAL DATA .....	27
Pipe .....	28
90° Elbows .....	29
45° Elbows .....	30
Tee .....	31
Reducer .....	32-33
Flange .....	34

---

# **Simtech Stress Relieved Piping Systems**

## **SYSTEM COMPOSITION**

*Dual Tech is a composite piping system consisting of Polypropylene (PP), PVDF, or a Pressure rated liner that is strengthened with a fiber glass reinforced thermoset resin system.*

*Thermoplastics, particularly Polypropylene (PP) and Polyvinylidene Fluoride (PVDF), have excellent chemical resistance to most process chemicals and wastes. However, they suffer a significant loss of physical properties (tensile strength, beam strength, etc.) when subjected to elevated temperature applications. FRP systems possess physical properties which far exceed thermoplastics but are decidedly inferior to thermoplastic's chemical resistance.*

*The objective of the Dual Tech System is to achieve a reliable and effective combination of these dissimilar plastic materials that enhances the performance of each component while minimizing the individual weaknesses. By successfully bonding the FRP Laminate onto the thermoplastic liner Simtech has created a piping product with capabilities which far exceed the potential of either piping component.*

*DUAL TECH PP- Reinforced Polypropylene Piping: 1" - 12"\**

*DUAL TECH VF - Reinforced Polyvinylidene Fluoride Piping: 1" - 8"\**

*\*LARGER SIZES AVAILABLE ON REQUEST.*

# Simtech Stress Relieved Piping Systems

## DUAL TECH PIPE LINERS

### **POLYVINYLIDIENE FLUORIDE (PVDF) -**

The PVDF liner used in Dual Tech is extruded (seamless) from natural unpigmented 100% pure Polyvinylidene Fluoride polymer. There are no additives or fillers which could be leached from the liner to contaminate the media. After extrusion the liner is annealed to relieve inherent stresses caused by the extrusion process.

**Chemical Compatibility** - PVDF possesses outstanding resistance to most inorganic chemicals, acids, salts, aromatic and aliphatic hydrocarbons, halogens, organic acids and alcohols.

PVDF is not suitable for certain polar solvents, hot concentrated alkalies, fuming sulfuric, amines or pyridine.

*Consult our Chemical Resistance Guide for specific applications.*

**Temperature Range** - PVDF can be subjected to continuous operating temperatures as high as 280°F.

**Permeability** - PVDF has one of the lowest permeation coefficients of all the fluorocarbon resins. It is particularly superior to PTFE and FEP.

### **POLYPROPYLENE (PP) -**

The PP liner used in Dual Tech is, in fact, 150 psi rated through 4" diameter and 90 psi rated 6" - 12" diameter. The liner is seamless, extruded and stress relieved. Produced from Isotatic Homopolymer the material has temperature stabilizers added to provide enhanced resistance to aggressive media at elevated temperatures.

**Chemical Compatibility** - Polypropylene is particularly suited for handling dilute acids, some strong acids, alkalis and organic solvents. PP should not be used for halogens, halogenated hydrocarbons, aromatics or highly concentrated oxidizing acids.

*Consult our Chemical Resistance Guide for specific applications.*

**Temperature Range** - Polypropylene can be subjected to continuous operating temperatures as high as 210°F.

**Permeability** - When compared to PVC and other more amorphous thermoplastics, polypropylene possesses a relatively high gas permeation coefficient. It is important to incorporate thick liners in PP lined composite systems. Any increase in the thickness produces a reduction in permeability disproportionately greater than the increase in thickness.

## RESIN SYSTEM

The standard resin system employed in the manufacture of Dual Tech is Ashland Chemical Company's Ashland Hetron 922, or equal Vinylester Resin with UV inhibitors.

# Simtech Stress Relieved Piping Systems

## PIPE PHYSICAL PROPERTIES

Note: Dual Tech is structurally reinforced (FRP) thermoplastic piping material. The mechanical properties of the thermoplastic liner are customarily ignored when considering the performance capabilities of a dual laminate material. The values shown below are representative of the wound structural reinforcing applied to the OD of the pipe. Those values are not representative of the potential of Dual Tech as a System. Reinforcement of Dual Tech fittings are performed by contact molding in accordance with NBS-PS-15-69. (Typical Properties are not to be interpreted as specifications.) or utilizing Dual Tech Quick Wraps

<b>Table 2: Typical Properties - Pipe</b>	
Tensile - Longitudinal [Accordance with ASTM D2105 (psi)]	7,000 @ 70°F 4,000 @ 200°F
Modulus Of Elasticity (10 <sup>6</sup> psi) [Accordance with ASTM D2105]	1.4 @ 70°F 0.60 @ 200°F
Poisson's Ratio	0.35 @ 70°F 0.72 @ 200°F
Hydro-Burst (10 <sup>3</sup> psi) [Accordance with ASTM D1599]	44 @ 70°F 32.1 @ 200°F
Thermal Expansion [Accordance with ASTM D696]	1.05 x 10 <sup>-5</sup> in / in / °F
Thermal Conductivity	1.3 BTU / FT <sup>2</sup> / hr / °F / inch
Flow Coefficient: Hazen-Williams Method	C = 150

<b>Table 3: Typical Properties of Contact Molded Laminate<sup>1</sup> with Derakane 470-36</b>	
Tensile Stress	18,800 psi @ 250°F
Fluxural Stress	24,100 psi @ 250°F
Fluxural Modulus	10.6 x 10 <sup>5</sup> psi @ 250°F

<sup>1</sup> Based on 1/4" Laminate w/ 40% glass content (constructed: V / M / M / WR / M / WR / M).

# **Simtech Stress Relieved Piping Systems**

## **SYSTEM PRESSURE RATING**

Both Dual Tech PP and Dual Tech VF Systems will require flanges for joining to pumps, tanks valves or other equipment. Only ANSI 150 lb. flanges are available with Dual Tech. Consequently Dual Tech is limited to 150 psig service at the corresponding maximum allowable operating temperature.

*Note: The hoop stress rating of the liner is not included in calculations to determine thickness of winding necessary to obtain pressure rating.*

**TABLE 4: SYSTEM PRESSURE RATING**

Normal Pipe Size	Internal (PSIG) Pressure Rating @		Max Allowed External Pressure (PSIG)	Nominal O.D. + PP & PVDF	Normal Weight per foot in lbs.		Standard Lengths Plain End (ft)
	200° F PP	280° F PVDF*			PP	PVDF	
1	150	150	250	1.50	0.4	0.5	16.4
1½	150	150	230	2.21	0.85	0.9	16.4
2	150	150	200	2.72	1.4	1.6	16.4
2½	150	150	140	3.19	1.8	2.0	16.4
3	150	150	75	3.78	2.4	2.4	16.4
4	150	150	40	4.65	2.9	3.2	16.4
6	150	150	32	6.70	5.6	5.5	16.4
8	150	150	27	8.36	9.0	8.5	16.4
10	150	150	20	10.33	15.2	14.0	16.4
12	150	150	19	12.96	21.5	20.0	16.4

\* PVDF can be used as high as 280°F continuous operating temperatures. Thermal cycled systems should not exceed 210°F.

\* Dimensions may vary slightly due to thickness of resin rich coating.

## **FLOW CHARACTERISTICS**

The surface finish on the ID of Dual Tech PP and Dual Tech VF is considerably smoother than the bore of steel pipe. In addition, since these materials are not subject to corrosion the coefficient of friction does not deteriorate with time and exposure as with steel pipe.

Coefficient of Friction Dual Tech Piping

Hazen-Williams Method:  $C = 150$

Pressure loss for Dual Tech PP is shown in Table 5: Chart PL-1 and Dual Tech VF is shown in Table 6: Chart PL-2. Table 7: Chart PL-3 provides equivalent footage to be added for fittings.

# Simtech Stress Relieved Piping Systems

## Table 5: PL-1 Pressure Loss for Simtech PP Pipe

V = Velocity of water in ft./s; P = Pressure drop in psi/100 ft. of pipe based upon the Hazen-Williams method : C = 150.

	Nominal Pipe Size																					
	1	1 1/4	1 1/2	2	2 1/2	3	4	6	8	10	12	12										
	V	P	V	P	V	P	V	P	V	P	V	P										
1	0.39	0.04	0.24	0.01																		
2	0.78	0.14	0.49	0.04	0.32	0.02																
5	1.95	0.75	1.22	0.24	0.79	0.08	0.50	0.03	0.03	0.01												
7	2.72	1.39	1.71	0.45	1.11	0.16	0.70	0.05	0.49	0.02												
10	3.89	2.70	2.45	0.87	1.58	0.30	1.00	0.10	0.70	0.04	0.03											
15	5.84	5.72	3.67	1.85	2.37	0.64	1.49	0.21	1.05	0.09	0.73	0.06	0.49	0.01								
20	7.78	9.74	4.90	3.15	3.16	1.09	1.99	0.36	1.41	0.15	0.97	0.10	0.65	0.02								
25	9.73	14.72	6.12	4.77	3.95	1.64	2.49	0.54	1.76	0.23	1.22	0.13	0.81	0.03								
30	11.70	20.63	7.34	6.68	4.74	2.30	2.99	0.75	2.11	0.32	1.46	0.17	0.98	0.05								
35			8.57	8.89	5.53	3.07	3.49	1.00	2.46	0.43	1.70	0.23	1.14	0.06	0.54	0.01						
40			9.79	11.38	6.32	3.92	3.98	1.27	2.81	0.55	1.94	0.28	1.30	0.08	0.62	0.02						
45			11.00	14.16	7.11	4.88	4.48	1.59	3.16	0.68	2.19	0.34	1.46	0.10	0.69	0.02						
50					7.90	5.93	4.98	1.93	3.52	0.83	2.43	0.47	1.63	0.13	0.77	0.03	0.59	0.01				
60					9.48	8.31	5.98	2.71	4.22	1.16	2.92	0.63	1.95	0.18	0.92	0.03	0.69	0.02				
70					11.10	11.10	6.97	3.60	4.92	1.54	3.40	0.81	2.28	0.24	1.08	0.04	0.79	0.02				
80							7.97	4.61	5.62	1.97	3.89	1.00	2.60	0.30	1.23	0.05	0.89	0.03				
90							8.96	5.73	6.33	2.46	4.38	1.22	2.93	0.38	1.39	0.06	0.98	0.03				
100							9.96	6.97	7.03	2.99	4.86	1.84	3.25	0.46	1.54	0.07	1.23	0.04	0.49	0.01		
125							12.50	10.50	8.79	4.52	6.08	2.56	4.06	0.69	1.92	0.11	1.48	0.05	0.95	0.02		
150									10.60	6.33	7.29	3.43	4.88	0.70	2.31	0.16	1.72	0.07	1.10	0.02		
175											8.51	4.39	5.69	1.29	2.69	0.21	1.97	0.09	1.26	0.03		
200											9.72	6.64	6.50	1.65	3.08	0.27	2.46	0.13	1.58	0.05	0.99	0.01
250											12.20	9.31	8.13	2.49	3.85	0.40	2.95	0.19	1.89	0.06	1.19	0.02
300													9.75	3.50	4.62	0.57	3.44	0.26	2.21	0.09	1.39	0.03
350													11.40	4.64	5.39	0.75	3.94	0.32	2.52	0.11	1.59	0.03
400															6.16	0.97	4.43	0.40	2.84	0.14	1.78	0.04
450															6.93	1.20	4.92	0.49	3.15	0.16	1.98	0.05
500															7.69	1.46	5.90	0.69	3.78	0.23	2.38	0.07
600															9.23	2.04	6.89	0.92	4.41	0.31	2.78	0.10
700															10.80	2.72	7.87	1.17	5.04	0.40	3.17	0.13
800																	8.85	1.46	5.67	0.49	3.57	0.16
900																	9.84	1.78	6.30	0.60	3.97	0.19
1000																			12.60	2.17	7.93	0.70
2000																					9.92	1.07
2500																						
5000																						
7500																						

FLOW - GPM

# Simtech Stress Relieved Piping Systems

## Table 6: PL-2 Pressure Loss for Simtech PVDF Pipe

V = Velocity of water in ft./s; P = Pressure drop in psi/100 ft. of pipe based upon the Hazen-Williams method : C = 150.

	Nominal Pipe Size																	
	1	1	1 1/4	1 1/4	1 1/2	1 1/2	2	2	2 1/2	2 1/2	3	3	4	4	4	6	8	
	V	P	V	P	V	P	V	P	V	P	V	P	V	P	V	P	V	P
1	0.36	0.03	0.21	0.01														
2	0.71	0.11	0.42	0.03	0.27	0.01												
5	1.78	0.60	1.06	0.17	0.67	0.06	0.41	0.02										
7	2.49	1.11	1.49	0.32	0.94	0.10	0.57	0.03	0.38	0.01								
10	3.55	2.16	2.12	0.62	1.35	0.20	0.81	0.06	0.54	0.02								
15	5.33	4.57	3.19	1.31	2.02	0.43	1.22	0.13	0.81	0.05	0.40	0.01						
20	7.10	7.79	4.25	2.24	2.69	0.74	1.62	0.21	1.07	0.08	0.60	0.02						
25	8.88	11.80	5.31	3.37	3.37	1.11	2.03	0.32	1.34	0.12	0.79	0.04	0.50	0.01				
30	10.70	16.50	6.37	4.73	4.04	1.46	2.43	0.45	1.61	0.17	0.99	0.06	0.62	0.02				
35			7.43	6.30	4.71	2.08	2.84	0.60	1.88	0.22	1.19	0.08	0.74	0.03				
40			8.50	8.06	5.38	2.66	3.24	0.78	2.15	0.29	1.39	0.11	0.87	0.03				
45			9.56	10.00	6.06	3.31	3.65	0.96	2.42	0.36	1.59	0.14	0.99	0.04				
50			10.62	12.20	6.73	4.02	4.05	1.17	2.69	0.43	1.79	0.17	1.12	0.05	0.59	0.01		
60					8.08	5.63	4.86	1.64	3.22	0.60	1.99	0.21	1.24	0.06	0.70	0.02		
70					9.42	7.49	5.67	2.18	3.76	0.80	2.38	0.29	1.49	0.09	0.82	0.02		
80					10.80	9.60	6.48	2.79	4.30	1.03	2.78	0.39	1.74	0.12	0.94	0.03		
90							7.29	3.47	4.83	1.28	3.18	0.49	1.99	0.16	1.05	0.03		
100							8.10	4.22	5.37	1.55	3.57	0.61	2.23	0.19	1.17	0.04	0.75	0.01
125							10.31	6.38	6.71	2.35	4.96	0.74	2.48	0.24	1.46	0.06	0.93	0.02
150									8.06	3.29	5.96	1.13	3.10	0.36	1.76	0.08	1.12	0.03
175									9.40	4.37	6.95	1.58	3.72	0.50	2.05	0.10	1.31	0.03
200									10.70	5.60	7.94	2.10	4.34	0.85	2.34	0.14	1.50	0.04
250											11.90	9.06	6.20	1.81	2.39	0.21	1.87	0.07
300													7.44	2.41	3.51	0.29	2.24	0.10
350													9.93	3.09	4.10	0.39	2.62	0.13
400													11.20	3.84	4.68	0.49	2.99	0.16
450														4.67	5.27	0.61	3.37	0.20
500															5.85	0.75	3.74	0.25
600															7.02	1.05	4.49	0.35
700															8.19	1.40	5.24	0.47
800															9.36	1.79	5.98	0.60
900															10.50	2.23	6.73	0.75
1000																	7.48	0.91

FLOW - GPM

# **Simtech Stress Relieved Piping Systems**

**Table 7: PL3 Pressure Drop for Fittings in Equivalent Feet of Pipe**

	Nominal Size												
	½"	¾"	1	1¼"	1½"	2"	2½"	3"	4"	6"	8"	10"	12"
90° Elbow	1.5	2.0	2.7	3.5	4.2	5.5	7.0	8.0	11.0	16.0	20.0	25.0	32.0
45° Elbow	0.8	1.0	1.3	1.7	2.1	2.7	3.5	4.0	5.5	8.0	10.0	12.5	15.0
Tee with flow through run	1.0	1.4	1.7	2.3	2.7	4.3	5.1	6.3	8.3	13.0	16.5	55.0	58.0

## **WATER HAMMER**

Shock waves or pressure surges commonly referred to as water hammer are caused by rapid or abrupt change in fluid velocity within the pipe system. In some cases the surges can attain a magnitude sufficient to damage the system. The amount of surge experienced is dependant upon the modulus of the pipe material, the density and velocity of the fluid, the line length and the speed at which flow is stopped or started.

Dual Tech pipe is capable of withstanding surges many times its rated pressure, however, it is recommended that the source of hammer be eliminated or reduced in order to insure long term system integrity.

Avoid:

- Valves that close or open instantly
- Starting pumps into empty discharge lines unless a slow opening valve is used to gradually increase flow
- Slow closing check valves

It may also be advisable to employ feedback loops or surge suppressors to eliminate hammer.

# Simtech Stress Relieved Piping Systems

## SUPPORTING DUAL TECH

Table 8A shows the recommended support spacing for Dual Tech Pipe. Adjustment factors for operating temperature and specific gravity of the media are indicated in 8B and 8C respectively. Multiply Factor 8A by the appropriate factor shown in 8B and then multiply the result by the correction factor in 8C to obtain the recommended support spacing.

**Table 8: Recommended Support Spacing**

Table 8A		Table 8B		Table 8C	
Nominal Size	Span @ 70°F *	Max. Oper. Temp. °F	Factor	Specific Gravity	Factor
1	8.5	100	.95	.90	1.02
1 1/2	10.0	125	.90	1.00	1.00
2	11.0	150	.85	1.10	.98
3	12.0	175	.75	1.25	.95
4	13.5	200	.65	1.50	.91
6	16.0	210	.62		
8	16.0	250	.40		
10	17				
12	19				

\* Maximum deflection at Midspan = .5 inches  
\* Interior (continuous) spans can be increased by 20%

# Simtech Stress Relieved Piping Systems

## HANGERS AND SUPPORTS

Most standard pipe supports or hangers are satisfactory for supporting Dual Tech. The most important consideration is that 'point' loading be avoided. Saddles must be used to cradle the pipe in the hanger or support. Saddles should encompass a  $120^{\circ}$  -  $180^{\circ}$  arc on the bottom of the pipe and the length of the saddle should be at least equal to the diameter of the pipe being supported. Saddles can be made of galvanized sheet metal (12 ga.) or from half sections of plastic pipe of a suitable wall thickness.

Figure B: Hanger with Support Saddle Detail

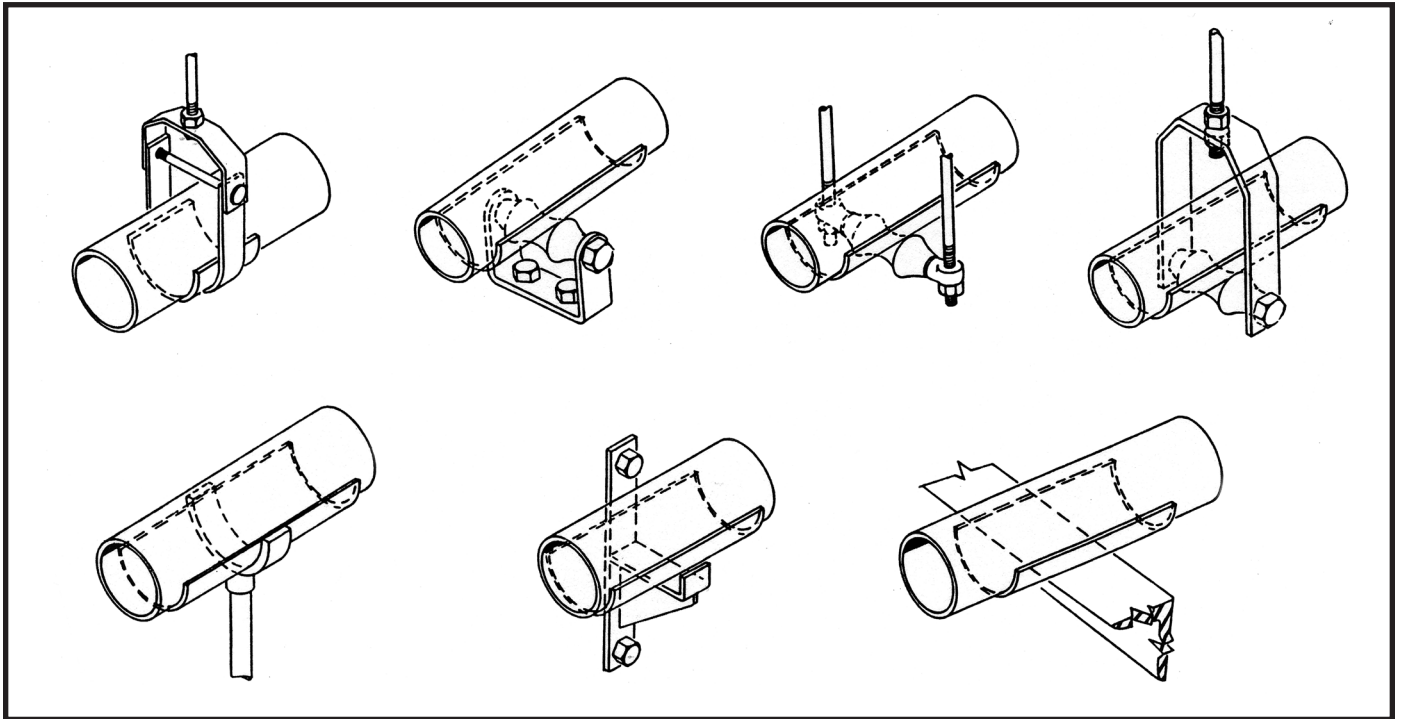

Figure C: Typical Guide Arrangement

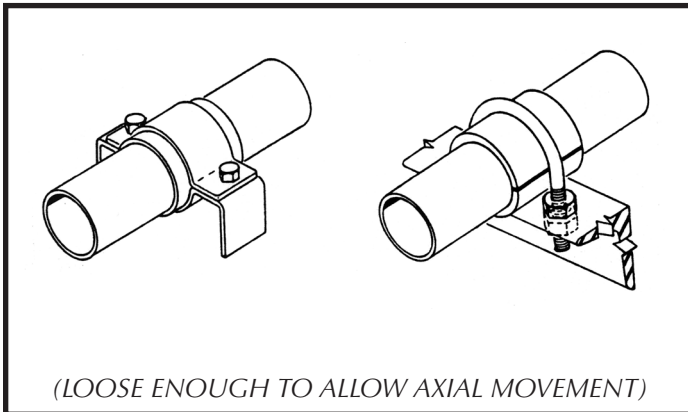
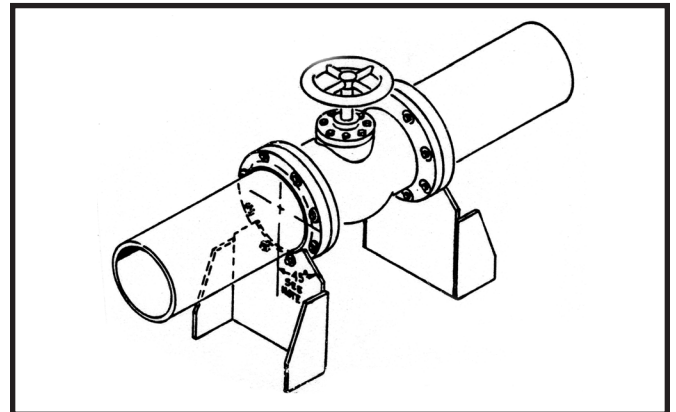

Figure D: Typical Valve Support & Anchor



# Simtech Stress Relieved Piping Systems

## ANCHORS AND GUIDES

Anchors must be designed to withstand the pressure and thermally induced endloads that will be produced by the pipe elements (see Table 10 & Table 11). Support saddles should be used at the top and bottom of the pipe within the anchor clamp or "U" bolt. 1/8" thick rubber sheeting should be used between the pipe OD and the support saddles to prevent damage to the pipe and to provide a positive grip on the pipe.

Figure E: Typical Anchors

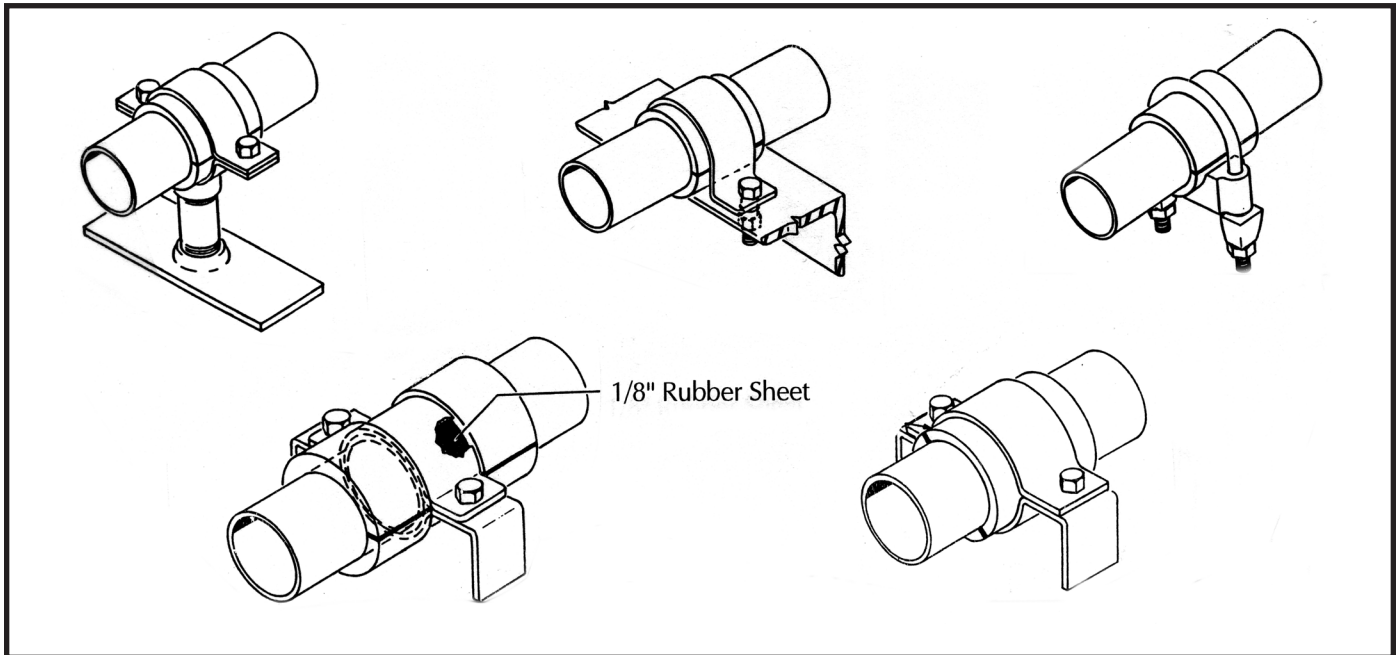

## THERMAL EXPANSION AND CONTRACTION

When subjected to temperature change Dual Tech will experience nearly twice the dimensional change of steel. Dimensional change will be the same for both Dual Tech PP and Dual Tech PVDF. This is because the thermoplastic liner pipe, which has an expansion coefficient 10 times that of FRP, is in fact limited to the dimensional change of the FRP reinforcement. Table 9 indicates Thermal Expansion/Contraction per 100 ft. of pipe which will occur at various temperature changes.

**Table 9: Thermal Expansion/Contraction per 100 ft. of Pipe (Inches)**

$\Delta T$	10	20	30	40	50	60	70	80	90	100	200
$\Delta L$	0.12	0.25	0.33	0.50	0.62	0.75	0.88	1.01	1.13	1.26	2.52

Note: Pressure induced dimensional change does occur however the change is not significant enough to effect design. Pressure induced axial end load is sufficient to effect design and is addressed later. (See Table 11 on the following page.)

# Simtech Stress Relieved Piping Systems

Dimensional change can be handled in one or more of several methods:

- Flexible design & installation employing directional changes to accommodate expansion or contraction,
- Employ expansion loops to create directional changes,
- Use mechanical expansion joints,
- Design and install a restrained system using anchors and guides,
- Use combinations of the above, as dictated by system layout.

End load values for expansion or contraction are the same. When designing restraints and anchors for expansion endload add the values shown in Table 10 and Table 11 to determine total endload.

**Table 10: Thermal Endloads Due to Temperature Change**

Nominal Size	$\Delta T$ (°F)								
	20	40	60	80	100	120	140	180	200
1"	108	217	327	436	544	653	762	980	1088
1½"	166	331	497	662	828	993	1159	1490	1655
2"	175	350	525	700	875	1050	1225	1575	1750
3"	296	524	785	1045	1308	1570	1832	2355	2617
4"	388	775	1161	1548	1935	2322	2709	3483	3870
6"	869	1739	2607	3475	4345	5214	6082	7821	8690
8"	1331	2662	3991	5322	6653	7984	9314	11976	13307
10"	1800	3601	5402	7203	9003	10804	12604	16206	18007
12"	3143	6288	9432	12578	15721	18865	22010	28299	31443

When designing to accommodate contraction due to low operating temperature and where the  $\Delta T$  exceeds 100°F, do not install a restrained system. Use changes of direction, loops and/or expansion joints to compensate for dimensional change.

**Table 11: Axial Endload Due to 100 psi Internal Pressure in a Restrained System**

Nom Ø	1	1½	2	3	4	6	8	10	12
lb <sub>f</sub>	68	120	160	400	650	1500	2500	4000	5600



# Simtech Stress Relieved Piping Systems

The amount of movement that can be accommodated by changes of direction is exhibited in Table 12 and is determined by pipe diameter and length of offset (A).

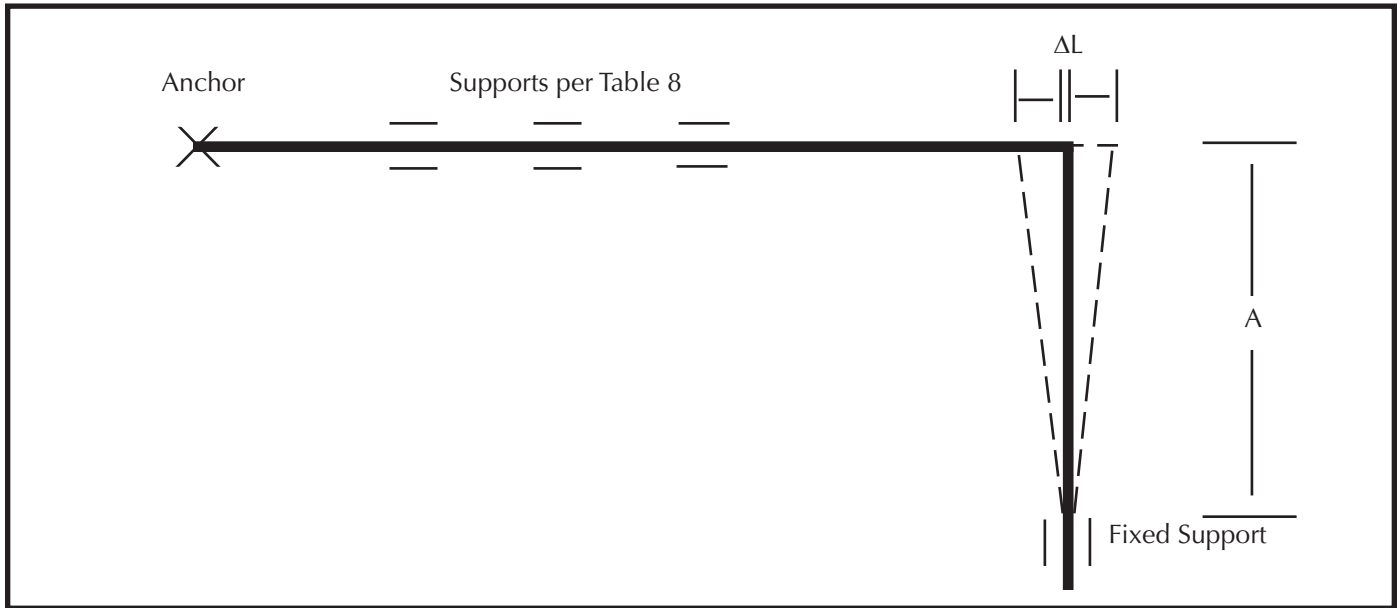

**Table 12: Length "A" Required Offset in Feet**

Pipe Ø	Change in Length ( $\Delta L$ in inches)									
	0.25	0.5	1	2	3	4	5	6	7	8
1	3	4.5	6.5	9	11	12	13	14	16	17
1 1/2	3	5	7	9.5	11.5	13	14.5	16.5	18	19
2	3.5	5	7	10	12	14	16	18	20	22
3	4.5	6	8	11	13	15.5	17	19	21	23
4	5	7	9	12	14.5	17.5	19	21	23	25.5
6	6	8	12	16	19	22	25	28	30	33
8	7	9.5	13	18	22	26	29	32	34	35.5
10	8	11	15	21	25	29	32	35	37	40
12	10	12	17	24	29	34	37	41	45	50

*Note: One or more moveable supports may be required for offset A if the length of A exceeds the support spacing outlined in Table 8.*

# Simtech Stress Relieved Piping Systems

## EXPANSION LOOPS

Often long straight runs will develop more dimensional change than can be accommodated by direction changes. When this occurs it will be necessary to design expansion loops or expansion joints into the system. The number of loops and dimensions of the offset legs will depend on pipe diameter, the amount of expansion to be absorbed and space available.

Figure G illustrates a typical loop arrangement. Dimensions for legs A are shown in Table 13. Loops can be installed either vertically or horizontally (leg B on the same elevation as the pipe). Horizontal installation is the most desirable if room permits.

Guide spacing required at the entrance and exit of the loop are shown in Table 14.

Figure G

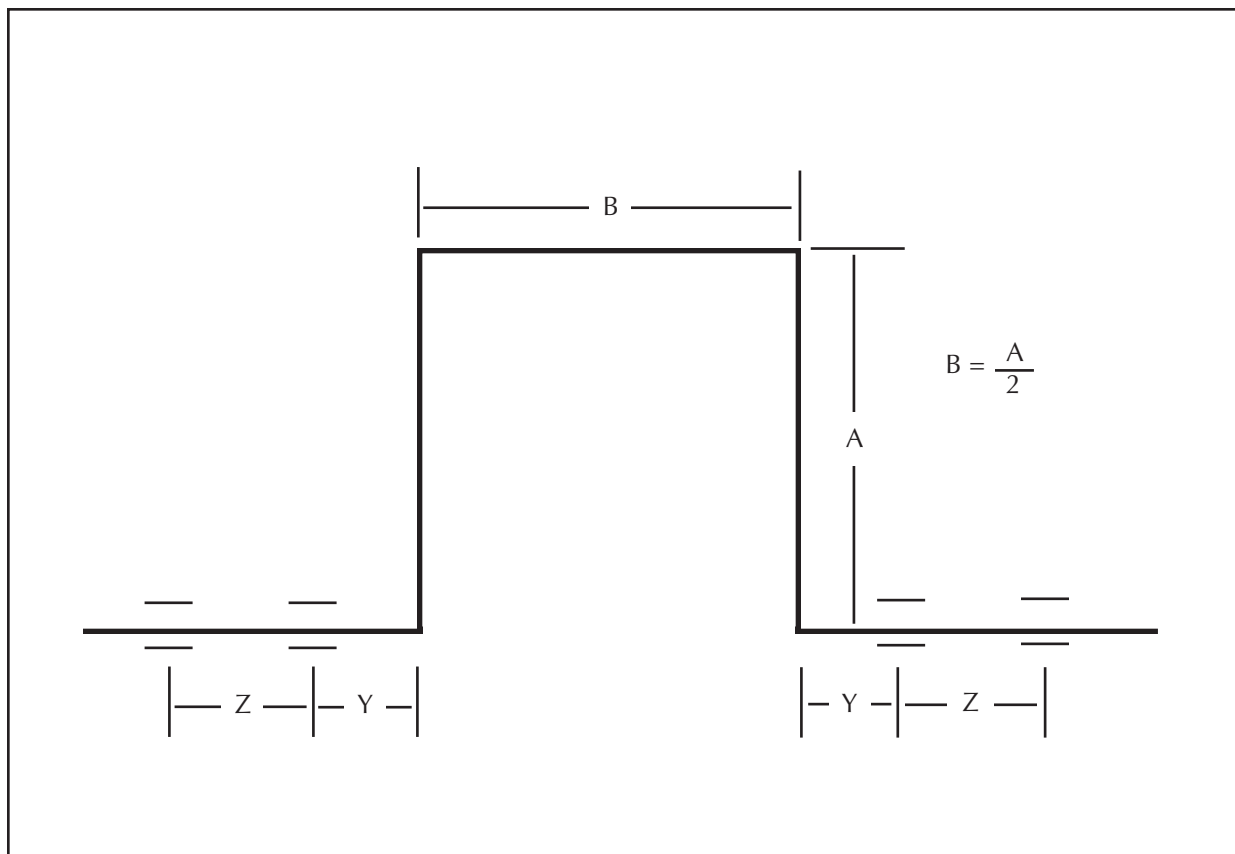

# Simtech Stress Relieved Piping Systems

**Table 13: Expansion Loop Design - Length of Leg "A" (Feet)**

Pipe Ø	Change in Length $\Delta L$ (inches)											
	0.25	0.5	1	2	3	4	5	6	7	8	9	10
1	2.5	3.5	5	6	7	9	10	11	12	13	14	15
1½	2.5	3.5	5	6.5	8	10	11	12	13	14	15	16.5
2	3	4	6	7.5	9	11	12.5	14	15	16	17	18
3	3.5	5	7.5	9.5	11.5	13	14.5	16	17.5	19	21	23
4	4	5.5	8	10.5	13	15	17	18	20	21	22.5	25
6	5	6.5	9	12	14.5	18	20	22	25	26	28	29
8	6	8	10	13	16	20	22	24	27	29.5	31.5	34
10	6.5	9	11	15	19.5	23	26	30	32	33.5	35	38
12	7	9.5	12.5	16.5	22	26	29	33	36	37.5	39	41

**Table 14: Guide Spacing at Loop or Expansion Joint Entrance and Exit (Feet)**

Dim. Feet	Pipe Ø									
	1	1½	2	3	4	6	8	10	12	
Y	0.6	0.5	0.6	1	1.3	2	2.6	3.3	4	
Z	1.1	1.7	2.3	3.5	4.6	7	9.3	11.6	14	

*Guide must be loose enough to allow axial movement but must not allow lateral movement.*

## EXPANSION JOINTS

The use of expansion joints to compensate for dimensional change is a relatively simple straight-forward solution to the problems resulting from expansion and/or contraction of the piping components. There are certain aspects of selection and installation which must be considered when employing expansion joints.

1. Bellows Type expansion joints are preferred because they require relatively low activation forces to initiate movement. The end load required to compress and/or extend the expansion joint must be lower than the end load values shown in Table 10.
2. Guides allowing axial movement must be utilized on the pipe at the entrance to the expansion joint in accordance with Table 14.
3. The remainder of the guides must allow axial movement and should be spaced in accordance with Table 15 (Guide Spacing for Restrained Piping) or Table 8 (Support Spacing) whichever is smaller.
4. Expansion joints must be installed at an appropriate mid-travel position taking into consideration the anticipated expansion or contraction that will be experienced.

# Simtech Stress Relieved Piping Systems

## RESTRAINED INSTALLATION

Space constraints or other factors may require installation of systems or portions of a system where the system is restrained and movement is prevented by anchoring. When restraining elements of a system consideration must be given to the following:

1. Anchors must be designed to withstand the end load introduced by compressive stress resulting from increased temperature (See Table 10).
2. Systems operating or subjected to temperatures lower than the temperature at time of installation will experience tensile stress with resultant tensile end load. Tensile end load must not exceed the Maximum Allowable Tensile Load Rating (See Table 16).
3. Thermally induced compressive stress may cause buckling unless the pipe is guided at proper intervals. Consult Table 15 for guide spacing. Compare spacing shown in Table 15 with support spacing shown in Table 8 and use the smaller value to determine guide spacing.

**Table 15: Guide Spacing in Feet**

Nom. Size	Temp. °F Increase								
	40	60	80	100	120	140	160	180	200
1	6.9	6	5.2	4.8	4.4	4	3.6	3.3	3
1½	7.8	6.6	5.8	5.2	4.7	4.2	3.7	3.5	3.3
2	8.5	7	6.2	5.5	4.9	4.2	3.9	3.7	3.5
3	12.2	10.2	8.4	7.8	7.1	6.5	6.2	5.9	5.5
4	15	13	11	10	9.2	8.6	8.1	7.8	7.5
6	Spacing shown in Table 8 will indicate closer spacing in these sizes.								
8									
10									
12									

**Table 16: Allowable Tensile Load (lbs.)**

Oper. Temp.	Nominal Size									
	1	1½	2	2½	3	4	6	8	10	12
75°F	675	980	1150	1470	1725	2450	4800	8500	11200	18560
200°F	340	485	550	695	830	1200	2380	4220	5470	9140

---

# **Simtech Stress Relieved Piping Systems**

## **JOINING PROCEDURE**

*Both Dual Tech PP and Dual Tech VF are joined with the same basic procedure. There are slight differences in the welding temperature and weld forces employed. (Refer to welding charts for details.) Dual Tech Piping is a dual laminate (composite) material, consequently it is necessary to employ technique that is specific to the material being joined.*

*The internal liner in Dual Tech is thermoplastic and is joined by butt fusion welding which is the easiest and most reliable method existing. In this procedure the ends of the pipes to be joined are melted and then fused together producing a weld through the entire cross sectional area of the liner. This weld can be visually inspected to determine weld quality to a very high degree of certainty.*

*The structural reinforcement applied as the external laminate of Dual Tech is a fiberglass reinforced thermosetting resin system (FRP). After welding of the liner is complete then the FRP is applied over the joint. Upon completion and proper curing the resultant joint will provide the full specified pressure rating with a 10 / 1 safety factor.*

# Simtech Stress Relieved Piping Systems

## END PREPARATION

Dualtech was designed to allow easy field installation with the use of SIMTECH's patent shaving tool & a standard 110v drill, the ends can be prepared with little effort

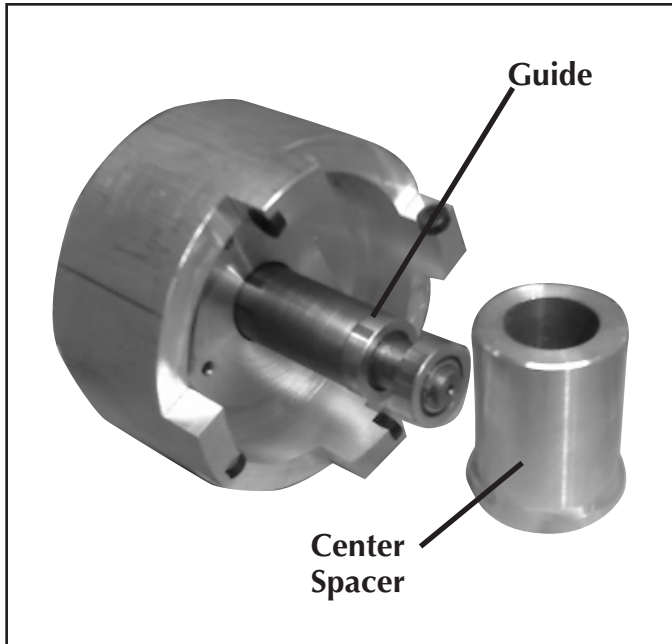

SIMTECH's Paten Shaver



Standard 110v Drill (Low RPM 200)

### Procedures For Shaving 1" - 6" Diameter Pipe:

1. Attach shaver to hand drill.
2. Firmly secure pipe in a pipe stand chain vice to prevent rotation.
3. Insert center spacer into the end of the pipe.
4. Confirm that pipe is secure, area is well ventilated, & safety glasses are on.
5. Insert metal guide on shaver into center spacer in the pipe.
6. Slowly engage trigger to rotate shaver **clockwise** as the shaver engages with the FRP layer slowly increase rpms. Shave until 1" to 1½" of the bare pipe is exposed. Stop drill motor before removing shaving tool from the end of the pipe.
7. Visually inspect prepared surface for FRP strands sand paper may be used to remove any excess FRP.
8. Clean prepared surface with acetone

# Simtech Stress Relieved Piping Systems

## Procedures for Welding:

The Dual Tech pipe is welded using standard, well established, butt fusion welding technique as outlined in ASTM D2657-87. Dual Tech 1" - 6" diameters are welded using the MiniPlast welding tool.

Pipe stands or supports will be required for this procedure. Stands or supports must be capable of supporting the sections to be welded while maintaining proper alignment so that angular deflection is avoided when making welds.

Both the Miniplast and the Maxiplast are equipped with clamping rings which will hold the pipe in correct alignment during the welding procedure but the pipe must be properly aligned prior to clamping.

Clamping rings on one side of the tool are stationary (do not move) and these are used to clamp onto pipe in the run that has already been joined. Clamping rings on the other end of the tool are movable and clamp onto the section (length) being added. See Figure M below.

*Note: When using the MaxiPlast be sure clamping heads are aligned square to the long axis of the machine.*

1. After properly adjusting stands or supports place pipe ends in clamping unit as shown with a minimum of 1/2" exposed on each side between the clamps.
2. Using the hand wheel or hydraulic unit, bring the pipe ends together until they touch. (If the pipe has been cut square the ends should butt together fairly flush.) Recheck pipe alignment to insure there is no angular deflection or axial misalignment. See Figure N.
3. After checking and correcting the alignment, separate the ends far enough to place & lock the planing unit into position in the clamping frame.
4. Turn on the planing unit and slowly bring the pipe ends into contact with the cutting blades. Continue shaving until a complete shaving of both ends has been achieved. (Usually 1 to 3

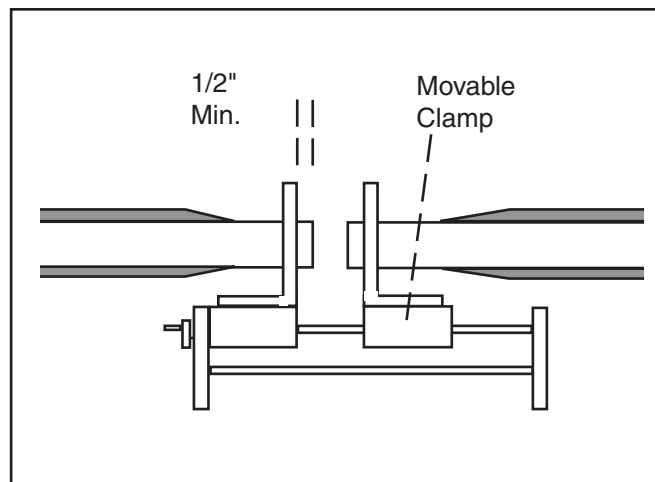

**Figure M**

# Simtech Stress Relieved Piping Systems

complete revolutions of the cutting blades.)

5. Turn off and remove the planing unit.

6. Bring the ends together to insure that they butt together flush around the entire circumference of the pipe. If not flush repeat #4. (Maximum gap allowed approx. 1/64 of an inch.)

7. Separate pipe ends and insert the heated welding platten (mirror) in position.

8. Bring both pipe ends into contact with the platten increasing pressure to the values shown on the weld chart.

9. Watch for the evidence of melt which is indicated by the formation of a small bead of melted material at both pipe ends around the entire periphery of the pipe. When the bead reaches the height shown on the welding chart reduce pressure to near zero but maintain contact with the platten.

10. Begin timing the heat-soak cycle when the pressure has been reduced to near zero. (Times shown on weld chart.)

11. When time is reached separate pipe ends and remove the heated platten.

12. Quickly bring the melted ends together (do not slam) and increase the weld pressure until the weld pressure shown on the welding chart is reached.

13. Leave pipe clamped in the tool while cooling. (See cooling times on the weld chart.)

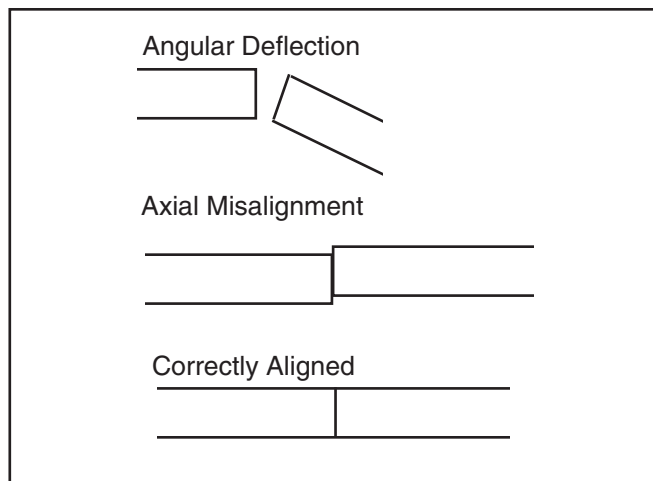

Figure N

# Simtech Stress Relieved Piping Systems

## PP Welding Chart:

Diameter & Wall Thickness		Weld Temp °C	Beginning Melt Pressure & Bead Height (Kg./Force)		Heating Time (Pressure at Near 0 Lbs. Force)	Change Over Time (Remove Heater & Gradually Increase to Weld Pressure) Seconds		Weld Pressure (Kg./Force)	Cooling Time Before Removing Clamps
			Pressure	Height		Seconds	Change Over		
1"	PN10	210	2	1/32"	40	4	4	2	4
1 1/2"	PN10	215	4	1/32"	50	5	6	4	6
2"	PN10	205	6	1/32"	60	5	6	6	7
3"	PN10	200	13	1/16"	90	6	8	13	10
4"	PN10	200	19	1/16"	100	6	10	19	12
6"	PN6	200	26	1/32"	100	6	8	26	14

For 8" pipe a hydraulic machine is used. Consult factory for welding charts

## PVDF Welding Chart:

Diameter & Wall Thickness		Weld Temp °C	Beginning Melt Pressure & Bead Height (Kg./Force)		Heating Time (Pressure at Near 0 Lbs. Force)	Change Over Time (Remove Heater & Gradually Increase to Weld Pressure) Seconds		Weld Pressure (Kg./Force)	Cooling Time Before Removing Clamps
			Pressure	Height		Seconds	Change Over		
1"	PN16	230	3.00	1/32"	30	4	5	3.00	3
1 1/2"	PN16	230	6.00	1/32"	40	4	5	6.00	5
2"	PN16	230	7.00	1/32"	45	4	5	7.00	5
3"	PN16	230	10.00	1/16"	40	4	5	10.00	6
4"	PN16	230	15.00	1/16"	50	4	5	15.00	7
6"	PN10	230	32.00	1/16"	70	4	5	32.00	10

For 8" pipe a hydraulic machine is used. Consult factory for welding charts

# Simtech Stress Relieved Piping Systems

## Flanged Dual Tech

Dual Tech is available as a totally flanged pipe system. Although a flanged system is considerably more expensive, there are occasions where it can not be avoided. We are prepared to spool-up to customer supplied dimensions.

Dual Tech flanges consist of a stub end and loose backing ring combination. This arrangement will require flange bolts which are longer than those used with steel flanges. It is also necessary to use washers under the bolt heads and nuts. The following chart indicates the appropriate flange bolt requirements.

Flange	Bolt Ø	Length	#Req'd	Washer OD
1"	1/2"	4"	4	1"
1 1/2"	1/2"	4"	4	1 1/16"
2"	5/8"	5"	4	1 1/4"
2 1/2"	5/8"	5"	4	1 1/4"
3"	5/8"	5"	4	1 3/8"
4"	5/8"	5"	8	1 3/8"
6"	3/4"	5 3/4"	8	1 1/2"
8"	3/4"	6"	8	1 1/2"
10"	7/8"	7 1/2"	12	1 3/4"
12"	7/8"	8"	12	1 3/4"

Flange bolts should be tightened in the sequence shown below. Tighten bolts in 2 passes. Bring bolts to 1/2 the torque values shown below on the first sequence then repeat the sequence tightening to the listed values.

NOTE: When using Dual Tech DTTS-Triple Seal Teflon Bonded Gaskets torque values can be reduced to 1/3 the values shown.

TORQUE VALUES			
Size	FT/lbs	Size	FT/lbs
1"	11	4"	18
1 1/2"	13	6"	25
2"	14.5	8"	28.5
2 1/2"	18	10"	36
3"	19	12"	43

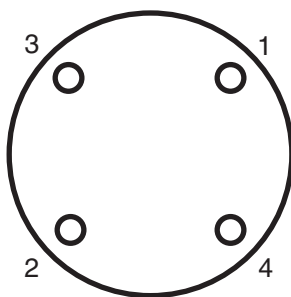

4 Hole Flange

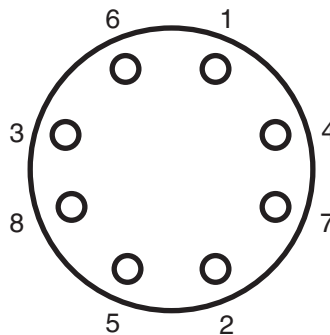

8 Hole Flange

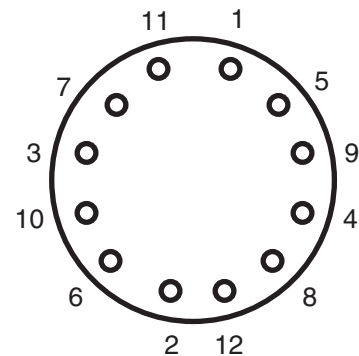

12 Hole Flange

# Simtech Stress Relieved Piping Systems

## Dual Tech Fieldwrap Kit.

QuickWrap® is a patented, easy to use, field overwrap kit for pipe joints & fittings, that eliminates the wet glass process in the field.

### READ ALL INSTRUCTIONS BEFORE OPENING PACKAGE! (Release water pressure from system when applicable)



**1** **Clean & rough up** area to be overwrapped. Remove any oil or foreign particles



**2** **Use gloves** enclosed and remove QuickWrap® from foil pouch. **Soak** in temperate water for 20 seconds.

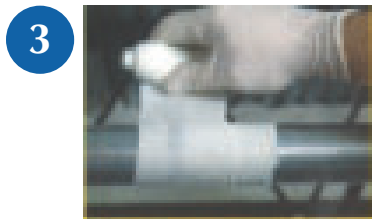

**3** **Wrap** QuickWrap®, using entire roll. Wrap as tightly as possible. Overwrap pipe joint or fitting completely until 2" overlap is achieved onto fiberglass.

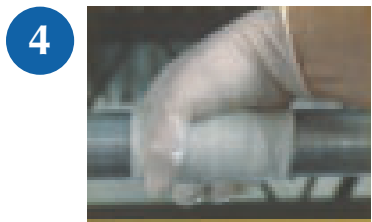

**4** **Squeeze and mold** QuickWrap® in the direction of wrap, removing excess water and spreading resin until tacky to touch (approx. 3 minutes). Allow 30 minutes for complete curing.

Pipe Diameter	Roll Size	Part #	Kit Examples
½" - 1"	2" x 5'	520	QW520
1¼" - 2"	3" x 9'	930	QW930
2½" - 4"	4" x 15'	415	QW415
4½" - 6"	4" x 30'	430	QW430

**Note:** For Fieldwraps of 8" and up, contact factory. Call 1-877-777-2467 to order

#### PRECAUTIONS:

The resin used in QuickWrap® will adhere to skin and clothing and may cause skin irritation. Protective gloves should be worn while handling. Care should be exercised to avoid contact with unprotected areas of skin and eyes. Swabbing lightly with alcohol or acetone will help in removing resin from skin (prior to set). Flush eyes with water 15 minutes and then contact physician. **Store in a cool, shaded area.**

---

---

# ***Simtech Stress Relieved Piping Systems***

NOTES:

# DualTech<sup>®</sup> Dimensional Data

# Simtech Stress Relieved Piping Systems - Dimensional Data

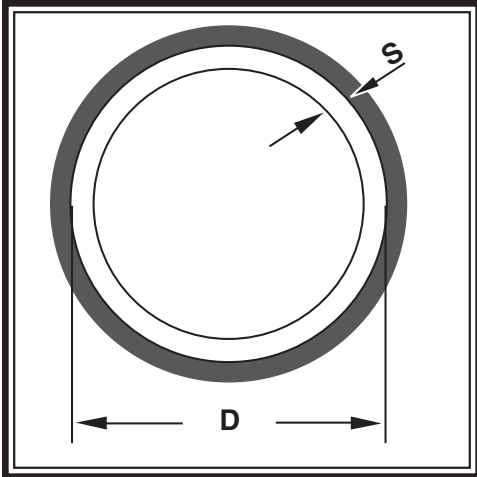

## DualTech Pipe

Description: DualTech Pipe

Material: Polypropylene or KYNAR® 740 PVDF

Connection: Butt Fusion

Polypropylene			
Nominal Size	D in	S in	Length Ft
1"	1.260	0.114	16.4
1½"	1.969	0.181	16.4
2"	2.480	0.228	16.4
3"	3.543	0.323	16.4
4"	4.331	0.394	16.4
6"	6.299	0.358	16.4
8"	7.874	0.449	16.4
10"	9.843	0.559	16.4
12"	12.402	0.705	16.4

PVDF			
Nominal Size	D in	S in	Length Ft
1"	1.260	0.094	16.4
1½"	1.969	0.118	16.4
2"	2.480	0.118	16.4
3"	3.543	0.169	16.4
4"	4.331	0.209	16.4
6"	6.299	0.193	16.4
8"	7.874	0.244	16.4

# Simtech Stress Relieved Piping Systems - Dimensional Data

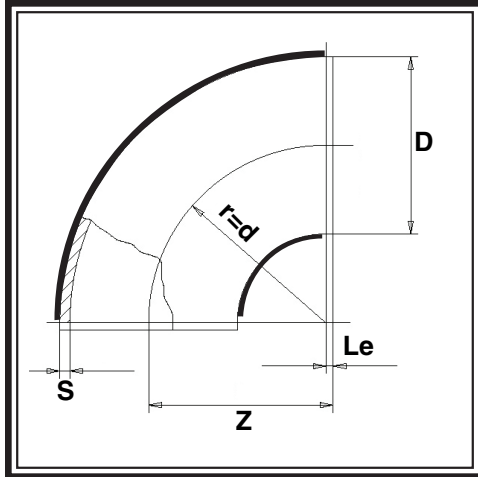

## DualTech Elbow: 90°

Description: DualTech Elbow: 90°

Material: Polypropylene or KYNAR® 740 PVDF

Connection: Butt Fusion

Polypropylene				
Nominal Size	D in	Le in	Z in	S in
1"	1.260	0.197	1.378	0.114
1½"	1.969	0.276	2.087	0.181
2"	2.480	0.276	2.598	0.228
3"	3.543	0.236	3.661	0.323
4"	4.331	0.472	4.528	0.394
6"	6.299	0.315	6.496	0.358
8"	7.874	0.748	8.110	0.449
10"	9.843	0.787	10.079	0.559
12"	12.402	0.866	12.756	0.705

1" to 2" supplied as bare fitting with wrap kits  
3" and above fittings supplied FPR Reinforced

PVDF				
Nominal Size	D in	Le in	Z in	S in
1"	1.260	1.024	1.811	0.094
1½"	1.969	1.102	2.283	0.118
2"	2.480	1.102	2.598	0.118
3"	3.543	0.906	3.543	0.169
4"	4.331	0.906	4.331	0.209
6"	6.299	1.299	6.299	0.193
8"	7.874	1.299	7.874	0.244

1" to 2" supplied as bare fitting with wrap kits  
3" and above fittings supplied FPR Reinforced

# Simtech Stress Relieved Piping Systems - Dimensional Data

## DualTech Elbow 45° - Extended Leg

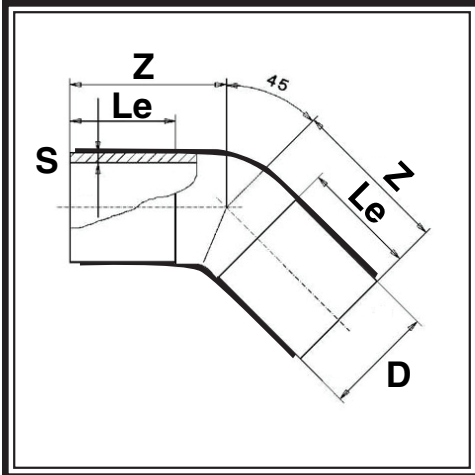

Description: DualTech Elbow 45° - Extended Leg

Material: Polypropylene or KYNAR® 740 PVDF

Connection: Butt Fusion

Polypropylene				
Nominal Size	D in	Le in	Z in	S in
1"	1.260	2.795	3.858	0.114
1½"	1.969	2.441	4.252	0.181
2"	2.480	2.598	4.528	0.228
3"	3.543	3.268	5.512	0.323
4"	4.331	3.661	6.299	0.394
6"	6.299	5.630	9.055	0.358
8"	7.874	5.984	10.236	0.449
10"	9.843	5.236	11.496	0.559
12"	12.402	6.063	14.567	0.705

1" to 2" supplied as bare fitting with wrap kits  
3" and above fittings supplied FPR Reinforced

PVDF				
Nominal Size	D in	Le in	Z in	S in
1"	1.260	1.024	1.417	0.094
1½"	1.969	1.181	1.654	0.118
2"	2.480	1.220	1.850	0.118
3"	3.543	1.457	2.244	0.169
4"	4.331	1.811	2.756	0.209
6"	6.299	2.441	3.937	0.193
8"	7.874	3.031	4.882	0.244

# Simtech Stress Relieved Piping Systems - Dimensional Data

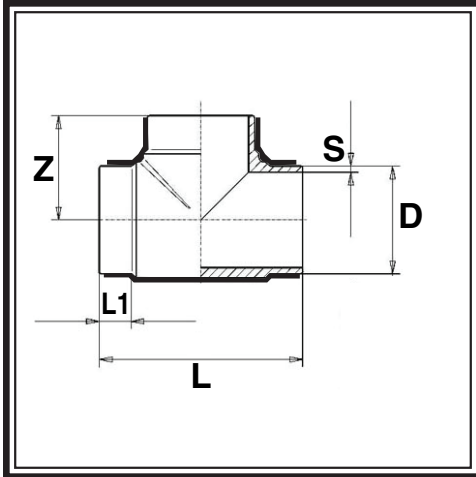

## DualTech Tee

Description: DualTech Tee

Material: Polypropylene or KYNAR® 740 PVDF

Connection: Butt Fusion

Polypropylene					
Nominal Size	D in	L in	L1 in	Z in	S in
1"	1.260	3.425	0.433	1.732	0.114
1½"	1.969	3.937	0.472	1.969	0.181
2"	2.480	5.039	0.669	2.638	0.228
3"	3.543	7.205	1.535	4.055	0.323
4"	4.331	10.039	2.165	5.157	0.394
6"	6.299	12.520	2.165	6.417	0.358
8"	7.874	17.126	3.465	8.465	0.449
10"	9.843	17.638	2.520	8.819	0.559
12"	12.402	22.283	3.228	11.142	0.705

1" to 2" supplied as bare fitting with wrap kits  
 3" and above fittings supplied FPR Reinforced

PVDF					
Nominal Size	D in	L in	L1 in	Z in	S in
1"	1.260	3.622	1.063	1.811	0.094
1½"	1.969	4.567	1.102	2.283	0.118
2"	2.480	5.197	1.102	2.598	0.118
3"	3.543	7.087	1.535	3.543	0.169
4"	4.331	8.661	1.890	4.331	0.209
6"	6.299	12.598	2.795	6.299	0.193
8"	7.874	15.748	3.150	7.874	0.244

# Simtech Stress Relieved Piping Systems - Dimensional Data

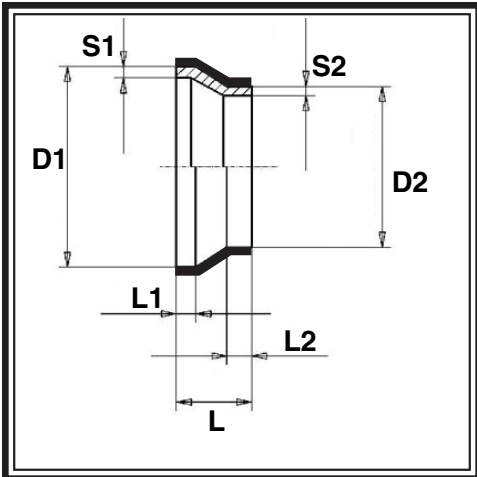

## DualTech Reducer

Description: DualTech Reducer

Material: Polypropylene

Connection: Butt Fusion

Polypropylene							
Nominal Size	D1 in	D2 in	L in	L1 in	L2 in	S1 in	S2 in
1½" x 1"	1.969	1.260	1.969	1.063	1.063	0.181	0.114
2" x 1"	2.480	1.260	2.362	1.063	0.984	0.228	0.114
2" x 1½"	2.480	1.969	2.362	1.142	1.063	0.228	0.181
3" x 1½"	3.543	1.969	2.913	0.866	0.787	0.323	0.181
3" x 2"	3.543	2.480	2.913	1.181	1.102	0.323	0.228
4" x 1½"	4.331	1.969	3.543	1.102	0.787	0.394	0.181
4" x 2"	4.331	2.480	4.134	1.614	1.378	0.394	0.228
4" x 3"	4.331	3.543	3.937	1.614	1.575	0.394	0.323
6" x 3"	6.299	3.543	5.433	2.087	1.614	0.358	0.323
6" x 4"	6.299	4.331	5.039	2.087	1.614	0.358	0.394
8" x 6"	7.874	6.299	5.709	2.441	2.047	0.449	0.358
10" x 6"	9.843	6.299	6.693	2.480	2.087	0.559	0.358
10" x 8"	9.843	7.874	7.087	2.520	2.520	0.559	0.449
12" x 8"	12.402	7.874	9.724	3.150	1.969	0.705	0.449
12" x 10"	12.402	9.843	9.173	3.307	2.520	0.705	0.559

1" to 2" supplied as bare fitting with wrap kits  
 3" and above fittings supplied FPR Reinforced

# Simtech Stress Relieved Piping Systems - Dimensional Data

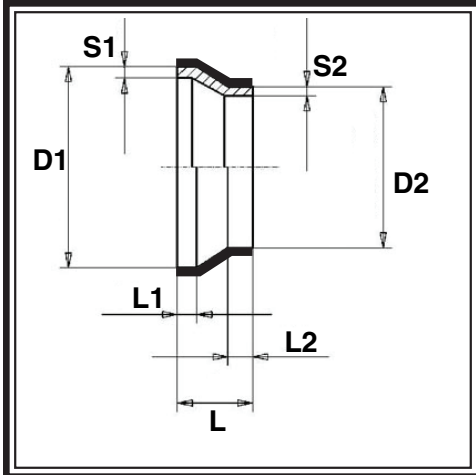

## DualTech Reducer

Description: DualTech Reducer

Material: KYNAR® 740 PVDF

Connection: Butt Fusion

PVDF							
Nom. Size	D1 in	D2 in	L1 in	L2 in	Z in	S1 in	S2 in
1½" x 1"	1.969	1.260	0.866	0.984	2.362	0.118	0.094
2" x 1"	2.480	1.260	0.866	0.984	2.559	0.118	0.094
2" x 1½"	2.953	1.969	0.945	0.984	2.559	0.118	0.118
3" x 2"	3.543	2.480	0.984	1.181	2.953	0.169	0.118
4" x 2"	4.331	2.480	1.181	1.181	3.543	0.209	0.118
4" x 3"	4.331	3.543	1.181	1.378	3.543	0.209	0.169
6" x 4"	6.299	4.331	1.575	1.575	4.724	0.193	0.209
8" x 6"	7.874	6.299	1.575	1.378	4.724	0.244	0.193

1" to 2" fittings supplied unwrapped  
 3" and above fittings supplied wrapped

# Simtech Stress Relieved Piping Systems - Dimensional Data

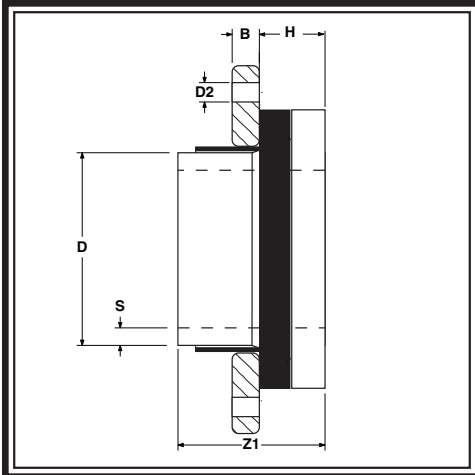

## DualTech Flange

Description:

DualTech Flange

Material- Stub End:  
Material-Backing Ring:

Polypropylene or KYNAR® 740 PVDF  
GRP Polypropylene w/ Steel Core -  
150 lbs. ANSI Drilling Pattern

Connection:

Butt Fusion

Polypropylene							
Nominal Size	D in	D2 in	B in	H in	Z1 in	S in	# Holes
1"	1.260	0.630	0.630	1.019	1.969	0.114	4
1½"	1.969	0.630	0.709	1.097	1.969	0.181	4
2"	2.480	0.748	0.709	1.216	2.205	0.228	4
3"	3.543	0.748	0.709	1.334	3.268	0.323	4
4"	4.331	0.748	0.709	1.373	3.307	0.394	8
6"	6.299	0.874	0.945	1.334	3.228	0.358	8
8"	7.874	0.874	0.945	1.609	4.764	0.449	8
10"	9.843	1.000	1.181	1.609	4.724	0.559	12
12"	12.402	1.000	1.339	1.649	6.457	0.705	12

Flange consists of molded PP stub end w/ FRP Reinforcement & GRP Polypropylene Backing Ring with Steel Core - 150lb

PVDF							
Nominal Size	D in	D2 in	B in	H in	Z1 in	S in	# Holes
1"	1.260	0.630	0.630	1.019	2.756	0.094	4
1½"	1.969	0.630	0.709	1.097	3.307	0.118	4
2"	2.480	0.748	0.709	0.979	2.835	0.118	4
3"	3.543	0.748	0.709	1.294	4.724	0.169	4
4"	4.331	0.748	0.709	1.137	3.189	0.209	8
6"	6.299	0.874	0.945	1.294	3.661	0.193	8
8"	7.874	0.874	0.945	1.491	4.016	0.244	8

Flange consists of molded PP stub end w/ FRP Reinforcement & GRP Polypropylene Backing Ring with Steel Core - 150lb

---

# ***Simtech Stress Relieved Piping Systems***

NOTES:

---

# **Simtech Stress Relieved Piping Systems**

## ***Simtech Industrial Products, Inc.***

47-A Runway Road, Levittown, PA 19057  
Phone (215) 547-0444 Fax 215-547-9129  
E-mail: info@SimtechUSA.com  
Web site: www.SimtechUSA.com

### **WARRANTY**

Simtech Industrial Products, Inc. products are warranted to be free from defects in materials and workmanship for one (1) year from date of shipment. No claim shall be permitted under this warranty unless Buyer gives Simtech Industrial Products, Inc. written notice of all respects in which Buyer claims the product to be defective. Notice must be received within ten (10) days from the date which the Buyer discovers, or should have discovered the defect. Buyer shall give Simtech Industrial Products, Inc. a reasonable opportunity to inspect the product after notice has been given. This warranty shall not apply to any products or components, which have been subjected to abnormal use, negligence or accident.

Seller's sole obligation under this warranty shall be limited solely on the repair or replacement, as elected by Simtech Industrial Products, Inc., of defective or non-conforming material. To the maximum extent permitted by law, Buyer irrevocably waives all claims for money damages relating to the condition, use and performance of the goods purchased. In no event shall Simtech Industrial Products, Inc. liability exceed the purchase price of the product sold by Simtech Industrial Products, Inc.

In no event, whether because of a breach of warranty or representation or any other cause, whether based upon contract, tort, warranty or otherwise, arising out of the performance or nonperformance by seller of its obligations under this agreement or with respect to the products sold pursuant here to; shall seller be liable for lost earnings, income or profits or indirect, incidental, liquidated or consequential damages.

The implied warranties of merchantability and fitness for a particular purpose except as set forth in this warranty, express or implied, are hereby disclaimed and excluded. Nothing shall be construed as an additional warranty unless specifically designated as such in writing and signed by Simtech Industrial Products, Inc.

Simtech Industrial Products, Inc. reserves the right, in its discretion, at any time and from time to time, to make changes to any specification, data or information contained herein.