

RUD Series

Pneumatic Ultra Pure Diaphragm Valve

Material: PP, PVDF, PFA
Size: 1/4" - 1/2"
Pressure Rating: 150 psi
Diaphragm: Teflon
Connections: Flare
 Butt Fusion
 FNPT (PP Only)

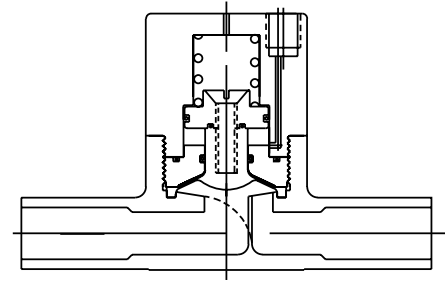

ISO 9002 CERTIFIED

Engineering Guide Specification

Materials of Construction:

PP: Class PP 110B76383 per ASTM D4101
PVDF: Type 1 per ASTM D3222

Guide Specification: The SIMTECH RUD series ultra pure diaphragm air valve features a compact molded thermoplastic valve especially designed to be used in critical high purity applications. Self-draining to prevent contamination and bacterial growth. Teflon diaphragm standard in all valves. Can handle high back pressure. Low actuating air pressure. Direct acting full flow and top entry for easy maintenance and minimum water hammer, as manufactured by SIMTECH.

Type 1: Air to open/spring to close.
 Type 2: Air to open/air to close.

Dimensional Data

d Inches	Port Type	A	B	C	D	Cv	Back Press	Air Press
1/4	FNTP	1.50	2.00	.350	1.500	1.87	60 psi	25-80
1/2	Butt Fusion	1.90	3.00	.420	4.740	4.32	70 psi	25-80
1/2	Flare	1.90	3.00	.420	4.250	4.32	70 psi	20-80

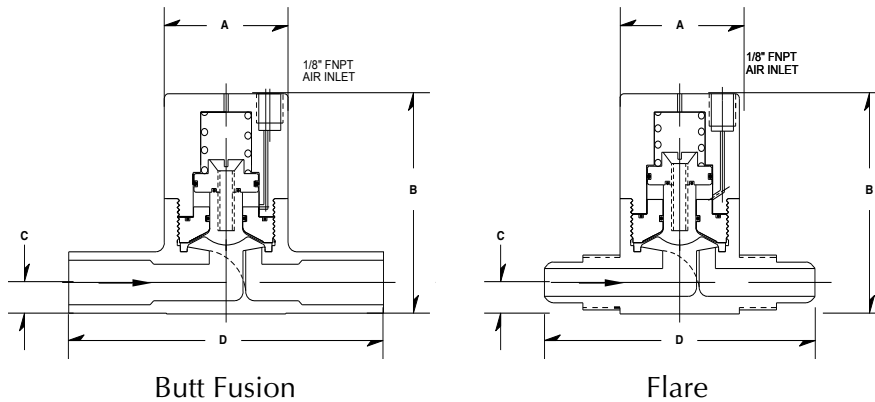

Pressure/Temperature Graph: Working PSI/Fahrenheit

