VS Series Swing Check Valve Operating, Installation & Maintenance Manual

Joining Installation Instructions

SIMTECH RECOMMENDS READING THE FOLLOWING INFORMATION PRIOR TO INSTALLING AND USING OUR VALVES, STRAINERS, CONTROLS AND OTHER ASSOCIATED PRODUCTS. FAILURE TO FOLLOW THESE INSTRUCTIONS MAY RESULT IN SERIOUS INJURY.

1. Simtech guarantees its products against defective material and workmanship only. Simtech assumes no responsibility for damage or injuries resulting from improper installation, misapplication, or abuse of any product.
2. Simtech assumes no responsibility for damage or injury resulting from chemical incompatibility between its products and the process fluids to which they are subjected. Compatibility charts provided in Simtech literature are based on ambient temperatures of 70F and are for reference only. Customer should always test to determine application suitability.
3. Consult Simtech literature to determine operating pressure and temperature limitations before installing any Simtech product. Note that the maximum recommended fluid velocity through any Simtech product is eight feet per second. Higher flow rates can result in possible damage due to the water hammer effect. Also note that maximum operating pressure is dependent upon material selection as well as operating temperature.
4. Simtech products are designed primarily for use with non-compressible liquids. They should NEVER be used or tested with compressible fluids such as compressed air or nitrogen.
5. Systems should always be depressurized and drained prior to installing or maintaining Simtech products.
6. Temperature effect on piping systems should always be considered when the systems are initially designed. Piping systems must be designed and supported to prevent excess mechanical loading on Simtech equipment due to system misalignment, weight, shock, vibration, and the effects of thermal expansion and contraction.
7. Because PVC and CPVC plastic products become brittle below 40F, Simtech recommends caution in their installation and use below this temperature.
8. Published operating torque requirements are based upon testing of new valves using clean water at 70F. Valve torque is affected by many factors including fluid chemistry, viscosity, flow rate, and temperature. These should be considered when sizing electric or pneumatic actuators.
9. Due to differential thermal expansion rates between metal and plastic, transmittal of pipe vibration, and pipe loading forces **DIRECT INSTALLATION OF METAL PIPE INTO PLASTIC CONNECTIONS IS NOT RECOMMENDED.** Wherever installation of plastic valves into metal piping systems is necessary, it is recommended that at least 10 pipe diameter in length of plastic pipe be installed upstream and downstream of the plastic valve to compensate for the factors mentioned above.

VS Series Swing Check Valves

Operating and Maintenance Instructions

1 DESCRIPTION

The VS series check valve is supplied with flanged ends for making the connection to the piping system in which it is installed. These valves are available in any of four (4) materials, (PVC, CPVC, Polypropylene or PVDF) Installation, operation and maintenance of these valves will be the same regardless of the materials of construction.

2 INSTALLATION

2.1 FLANGED CONNECTION:

Flange bolts should be tight enough to slightly compress the gasket and make a good seal, without distorting or putting excessive stress on the flanges. Suitable washers should be used between the bolt head and flange and the nut and flange. Bolts should be tightened in alternating sequence.

RECOMMENDED FLANGE BOLT TORQUE

VALVE SIZE	BOLT DIA.	TORQUE FT. LBS.
1/2"	1/2"	10-15
3/4"	1/2"	10-15
1"	1/2"	10-15
1-1/2"	1/2"	10-15
2"	5/8"	15-25

FLANGE SIZE	BOLT DIA.	TORQUE FT. LBS.
2-1/2"	5/8"	20-25
3"	5/8"	20-25
4"	5/8"	20-25
6"	3/4"	30-40
8"	7/8"	33-50

NOTE: USE WELL LUBRICATED METAL BOLTS AND NUTS. USE SOFT RUBBER GASKETS.

3 VALVE OPERATION

- 3.1. Valve must be installed observing the flow arrow molded into the side of the valve body.
- 3.2. Valve can be used in the vertical or horizontal positions.

4 MAINTENANCE

4.1. No lubrication is required.

4.1.1 The swing check disc (part # 3) may be replaced. To remove the swing check disc by taking valve bonnet (part # 2) off and sliding swing arm shaft out. On the lever and weight option a set screw in the disc will need to be completely removed before sliding disc out.

4.1.2 Swing arm attachment:

Care must be taken to install the valve with enough room for the swing arm weight to rotate 90 degrees freely. Compression fitting on swing arm may need tightening after installation. Care must be taken not to over tighten the compression fitting inhibiting the motion of the weight and swing arm.

Parts Listing

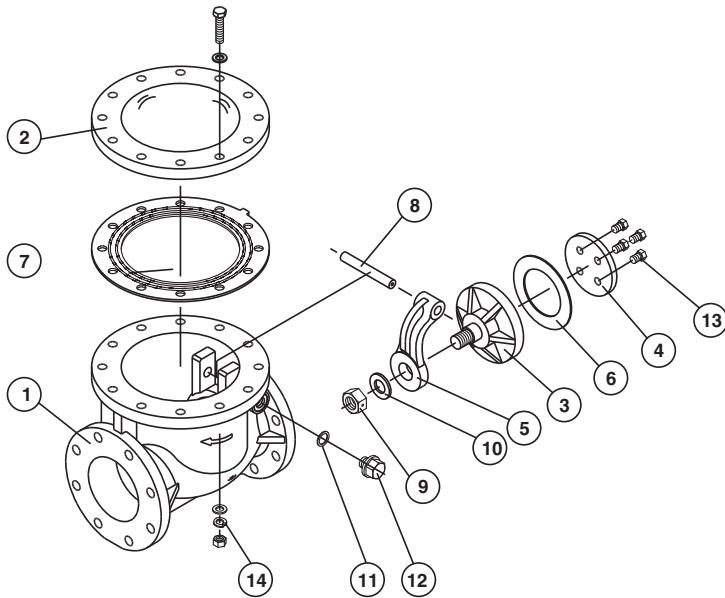

Number	Description	Material	Qty
1	Body	PVC, CPVC, PP, PVDF	1
2	Bonnet	PVC, CPVC, PP, PVDF	1
3	Disc	PVC, CPVC, PP, PVDF	1
4	Disc Holder	PVC, CPVC, PP, PVDF	1
5	Sway Arm	PVC, CPVC, PP, PVDF	1
6	Disk Gasket	EPDM, FPM, NBR, PTFE	1
7	Gasket	EPDM, FPM, NBR, PTFE	1
8	Shaft	PTFE	1
9	Disk Nut	PVC, CPVC, PP, PVDF	1
10	Disk Washer	PVC, CPVC, PP, PVDF	1
11	Sheet Gasket	EPDM, FPM, NBR, PTFE	1
12	Sheet Bolt	PVC, CPVC, PP, PVDF	1
13	Disc Bolt	PVC, CPVC, PP, PVDF	4-8
14	Bolt Sets	Stainless Steel - 304	8-12

Swing Check Lever / Weight Option

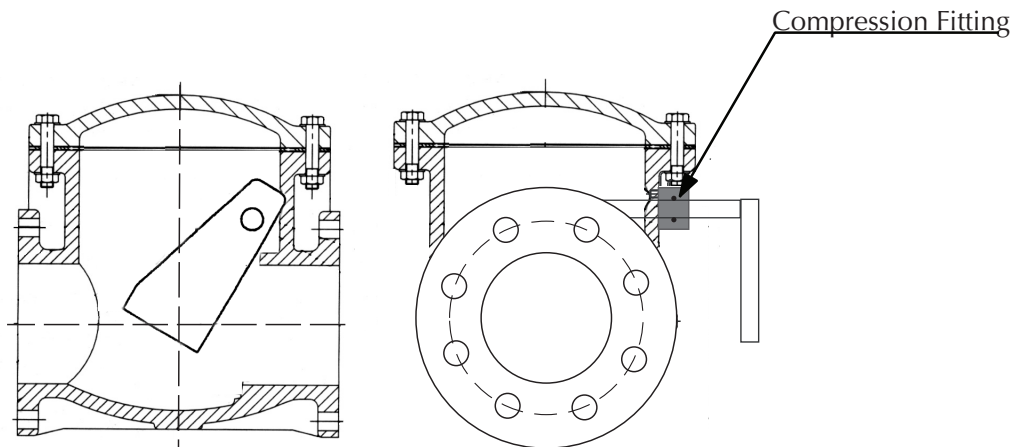

- External Lever & Weight
- Made from thermoplastic
- Assists Disc in Closing