

**WC Series:  
Wafer Check Valve**

**Operating, Installation  
&  
Maintenance Manual**

*Corrosion Resistant Fluid and  
Air Handling Systems.*

**SIMTECH**

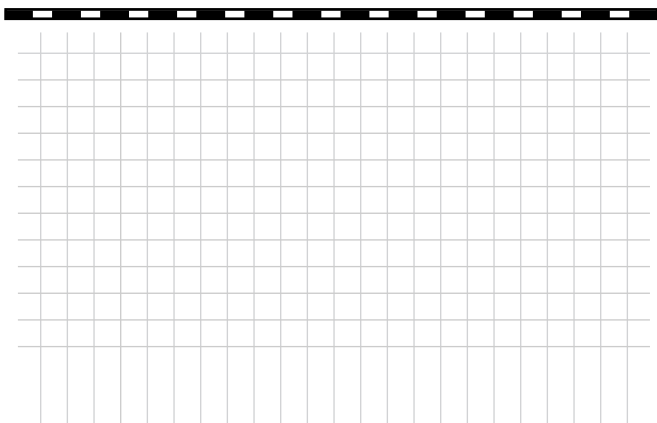

---

**SIMTECH**  
**47-A Runway Road, Levittown, Pa 19057,**  
**PH: 215-547-0444; Fax: 215-547-3410**

**Installation Instructions For Simtech Valves**

**SIMTECH RECOMMENDS READING THE FOLLOWING INFORMATION PRIOR TO INSTALLING AND USING OUR VALVES, STRAINERS, CONTROLS AND OTHER ASSOCIATED PRODUCTS.**

**FAILURE TO FOLLOW THESE INSTRUCTIONS MAY RESULT IN SERIOUS INJURY.**

1. Simtech guarantees its products against defective material and workmanship only. Simtech assumes no responsibility for damage or injuries resulting from improper installation, misapplication, or abuse of any product.
2. Simtech assumes no responsibility for damage or injury resulting from chemical incompatibility between its products and the process fluids to which they are subjected. Compatibility charts provided in Simtech literature are based on ambient temperatures of 70F and are for reference only. Customer should always test to determine application suitability.
3. Consult Simtech literature to determine operating pressure and temperature limitations before installing any Simtech product. Note that the maximum recommended fluid velocity through any Simtech product is eight feet per second. Higher flow rates can result in possible damage due to the water hammer effect. Also note that maximum operating pressure is dependent upon material selection as well as operating temperature.
4. Simtech products are designed primarily for use with non-compressible liquids. They should NEVER be used or tested with compressible fluids such as compressed air or nitrogen.
5. Systems should always be depressurized and drained prior to installing or maintaining Simtech products.
6. Temperature effect on piping systems should always be considered when the systems are initially designed. Piping systems must be designed and supported to prevent excess mechanical loading on Simtech equipment due to system misalignment, weight, shock, vibration, and the effects of thermal expansion and contraction.
7. Because PVC and CPVC plastic products become brittle below 40F, Simtech recommends caution in their installation and use below this temperature.
8. Published operating torque requirements are based upon testing of new valves using clean water at 70F. Valve torque is affected by many factors including fluid chemistry, viscosity, flow rate, and temperature. These should be considered when sizing electric or pneumatic actuators.
9. Due to differential thermal expansion rates between metal and plastic, transmittal of pipe vibration, and pipe loading forces **DIRECT INSTALLATION OF METAL PIPE INTO PLASTIC CONNECTIONS IS NOT RECOMMENDED.** Wherever installation of plastic valves into metal piping systems is necessary, it is recommended that at least 10 pipe diameter in length of plastic pipe be installed upstream and downstream of the plastic valve to compensate for the factors mentioned above.

**FLANGED CONNECTION:**

Flange bolts should be tight enough to slightly compress the gasket and make a good seal, without distorting or putting excessive stress on the flanges. Suitable washers should be used between the bolt head and flange and the nut and flange. Bolts should be tightened in alternating sequence.

**RECOMMENDED FLANGE BOLT TORQUE**

FLANGE SIZE	TORQUE FT. LBS.	FLANGE SIZE	TORQUE FT. LBS.
3"	20 - 30	8"	33 - 50
4"	20 - 30	10"	80-110
6"	33 - 50	12"	80-110

**RECOMMENDED FLANGE BOLT TORQUE SEQUENCE**

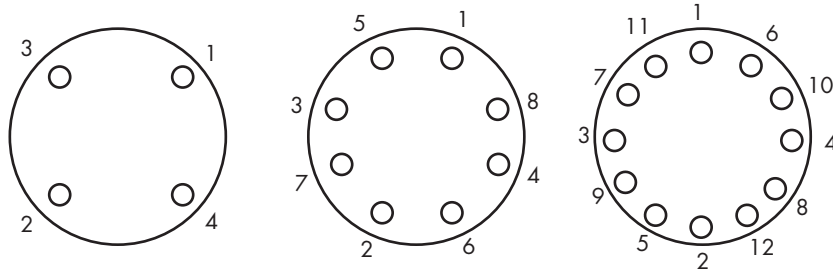

**NOTE: USE WELL LUBRICATED METAL BOLTS AND NUTS. USE SOFT RUBBER GASKET**

**SIMTECH RECOMMENDS EXTREME CAUTION MUST BE TAKEN WHEN WORKING ON THIS VALVE. THE PIPING SYSTEM MUST BE DEPRESSURIZED AND DRAINED. PROPER CARE MUST BE TAKEN. CONSULT M.S.D.S. (MATERIAL SAFETY DATA SHEETS) INFORMATION REGARDING YOUR SPECIFIC APPLICATION AND MEDIA**

## WC SERIES SWING CHECK VALVE SPRING PRESSURE SPECIFICATIONS-FIELD ASSEMBLY

The valves with spring assisted closing and position indicator are assembled with two compression springs. Please read the table below carefully and reinstall the proper springs for the required system pressure. No spring change is required for system pressure between 90 - 150 PSI (PVC, PPGF and PVDF). Please be aware that PP valves are only rated for a maximum pressure of 90 PSI at 72° F. One spring must be removed on PP valves. All materials are NSF 61 approved and are in conformance with the European ROHS requirements.

	COMBINATION OF SPRINGS 1 & 2	SPRING 1	SPRING 2
SYSTEM PRESSURE	90 -150 PSI	25 - 90 PSI	1 - 50 PSI

	PP	PPGF	PVDF	PVC
VALVE MAX. PRESSURE	90 PSI @ 72° F	150 PSI @ 72° F	150 PSI @ 72 F	150 PSI@72F

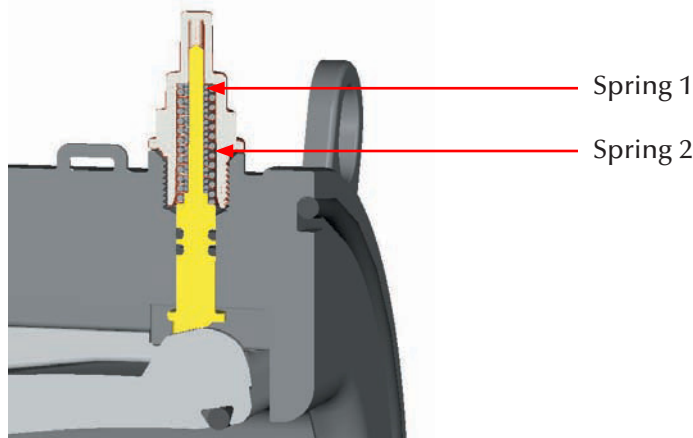

## Parts Listing

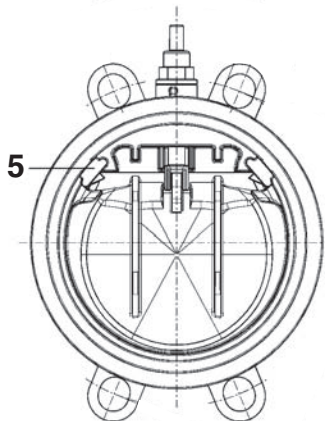
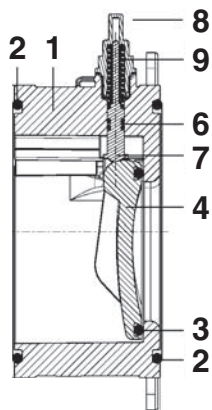

	Parts Listing:	Material
1	Body	PVC / PP / PVDF
2	O-Ring	EPDM / VITON (FPM)
3	Disk O-Ring	EPDM / VITON (FPM)
4	Disk	PVC / PP / PVDF
5	Disk Retainer	PVC / PP / PVDF
6	Stem O-Ring	EPDM / VITON (FPM)
7	Indicator Stem	PVDF
8	Indicator Cover	CLEAR ABS
9	Spring	304 SS