

# DVS Series

## Diaphragm Valve - Manual

<b>Material:</b>	PP or PVDF
<b>Size:</b>	20mm - 63mm True Union Socket 20mm - 110mm Spigot ½" - 4" ANSI Flanged
<b>Seal/Diaphragm:</b>	EPDM, FPM, or TEFLON
<b>Connections:</b>	Metric Socket (True Union) Metric Spigot (Non-Union) ANSI Flanged



**ISO 9002 CERTIFIED**

## Engineering Guide Specification

### Materials - Body:

- PP:** per ASTM D4101
- PVDF:** Type 1 per ASTM D3222
- Diaphragms:** EPDM, FPM or PTFE
- Union Seals:** EPDM or FPM

**Guide Specification:** Diaphragm valves shall be weir pattern body molded from the material indicated. Diaphragms shall be as indicated. (PTFE diaphragm shall be two piece assembly consisting of solid PTFE diaphragm with a reinforced EPDM backing cushion.) Visual indicator is standard, as manufactured by SIMTECH.

## Special Features

- Position indicator standard
- Glass Filled PP bonnet on all models
- Stainless steel assembly bolts
- Bottom Fasteners for Anchoring / Panel Mount
- High Cv Value for better flow
- Precise Flow Control
- Ergonomic handle for easy operation

## Pressure Loss

**Pressure Loss Curve (Standard Values for H<sub>2</sub>O, 20°C)**

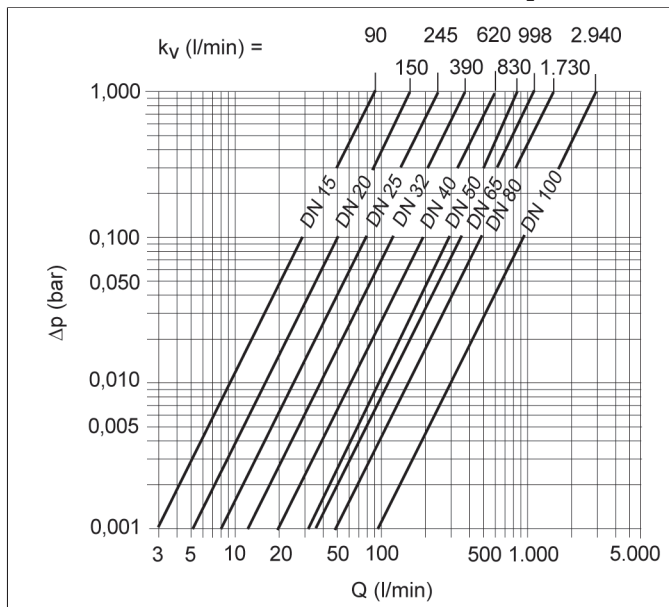

$\Delta P$  = Pressure Loss  
Q = Flow

### Pressure loss and $k_v$ value

The diagram shows the pressure loss  $\Delta P$  in relation to the flow Q.

### Conversion aid:

$$c_v = k_v * 0.07$$

$$f_v = k_v * 0.0585$$

### Units:

$k_v$  (l/min)  
 $c_v$  (gal/min) US  
 $f_v$  (gal/min) GB

# DVS Series

## Pressure/Temperature Graph:

Pressure/Temperature Diagram

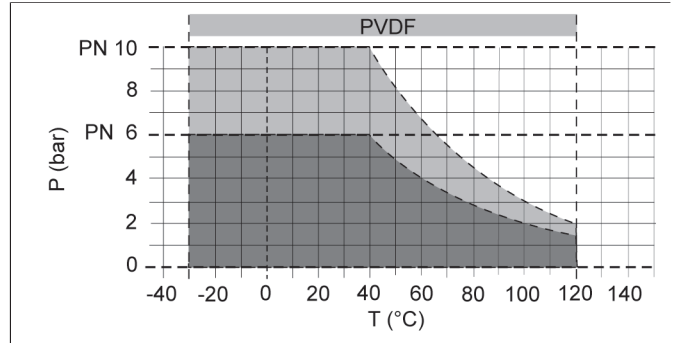
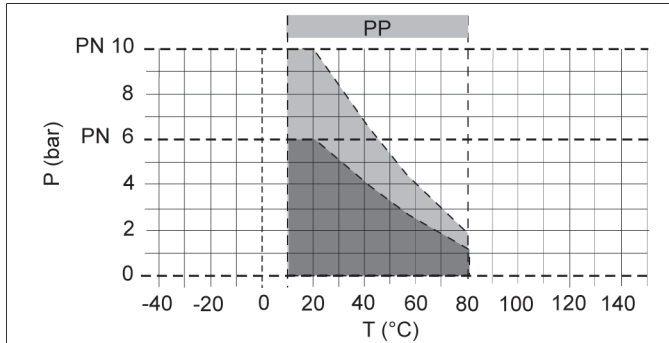

P = Operating Pressure

T = Temperature

The pressure/temperature limits are applicable for the stated nominal pressures and a computed operating life factor of 25 years. These are standard values for harmless media (DIN 2403), to which the valve material is resistant. For other media please refer to the chemical resistance guide. The durability of wear parts depends on the operating conditions of the application. For temperatures below 0°C (PP < +10°C) please specify the precise operating conditions of the application. The rated pressure depends on the valve size and material.

## Flow Rate

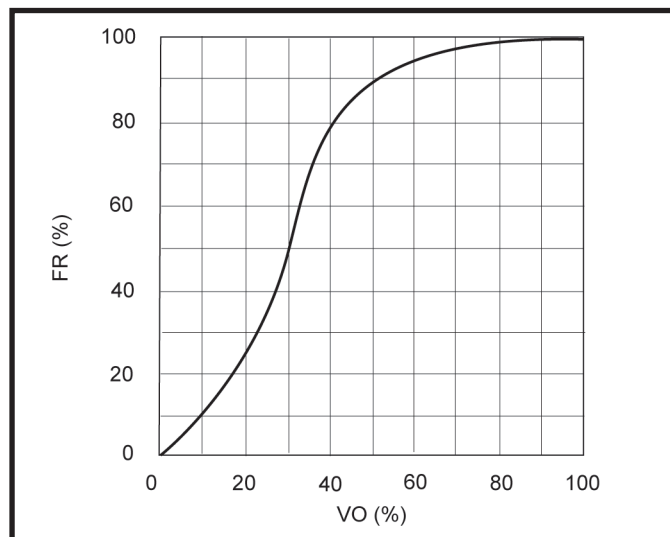

VO = valve opening

FR =  $K_v$  value

# DVS Series

## Dimensional Data - Spigot

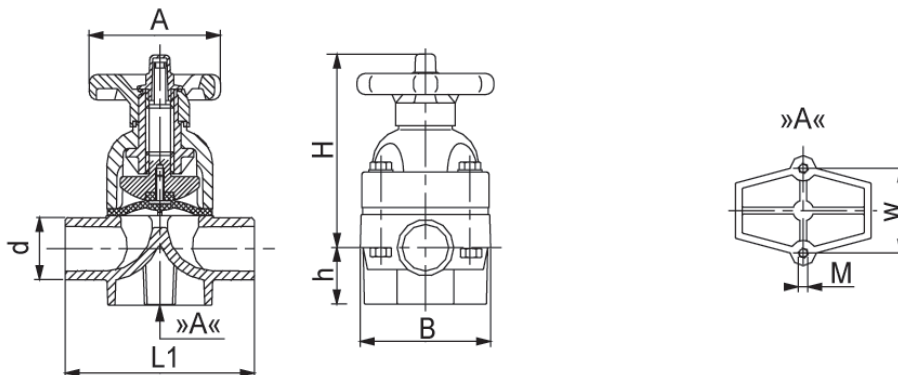

Nom. Size	A	B	d	h	H	L1	M	w
½"	3.54	2.83	0.79	1.02	3.86	4.88	M6	1.02
¾"	3.54	2.83	0.98	1.02	4.02	5.67	M6	1.02
1"	3.94	3.62	1.26	1.02	5.16	6.06	M6	1.02
1½"	3.94	3.62	1.57	1.57	5.31	6.85	M8	1.77
1½"	6.30	4.69	1.97	1.57	6.65	7.64	M8	1.77
2"	6.30	4.69	2.48	1.57	6.89	8.82	M8	1.77
2½"	7.48	6.97	2.95	2.13	9.65	11.18	M12	3.94
3"	7.48	6.97	3.54	2.13	9.65	11.81	M12	3.94
4"	9.45	8.54	4.33	2.52	11.22	13.39	M10	3.94

## Dimensional Data - True Union

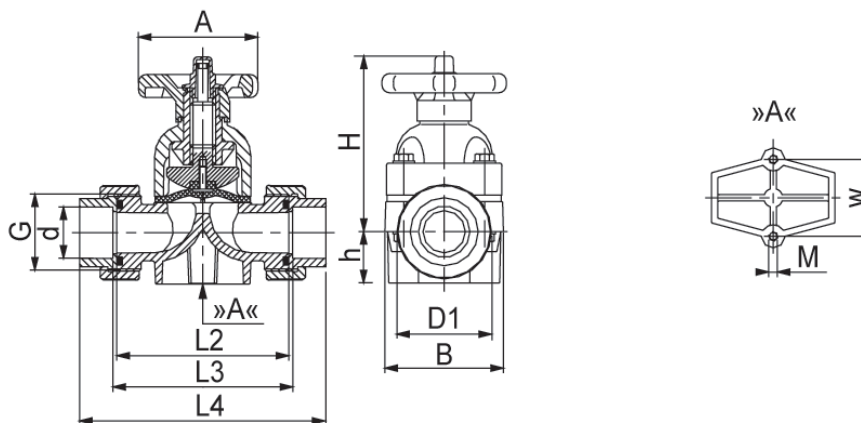

Nom. Size	A	B	d	D1 - PP	D1 - PVDF	h	H	L2	L3	L4 - PP	L4 - PVDF	M	w
½"	3.54	2.83	0.79	1.81	1.85	1.02	3.86	3.54	3.78	4.92	5.04	M6	1.02
¾"	3.54	2.83	0.98	2.20	2.24	1.02	4.02	4.25	4.49	5.75	5.91	M6	1.02
1"	3.94	3.62	1.26	2.60	2.52	1.02	5.16	4.57	4.80	6.22	6.38	M6	1.02
1½"	3.94	3.62	1.57	3.11	3.07	1.57	5.31	5.28	5.51	7.13	7.24	M8	1.77
1½"	6.30	4.69	1.97	3.43	3.50	1.57	6.65	6.06	6.30	8.15	8.27	M8	1.77
2"	6.30	4.69	2.48	4.21	4.29	1.57	6.89	7.24	7.48	9.61	9.76	M8	1.77

# DVS Series

## Dimensional Data - Flanged

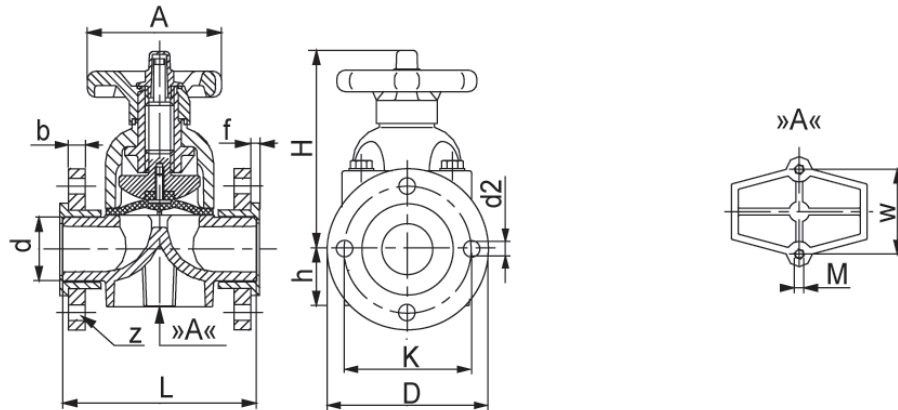

Nom. Size	A	b - PP	b - PVDF	d	d2	D	f	h	H	K	L	M	w	z
½"	3.54	0.47	0.51	0.79	0.55	3.74	0.24	1.02	3.86	2.56	5.12	M6	1.02	0.16
¾"	3.54	0.55	0.57	0.98	0.55	4.13	0.28	1.02	4.02	2.95	5.91	M6	1.02	0.16
1"	3.94	0.59	0.61	1.26	0.55	4.53	0.28	1.02	5.16	3.35	6.30	M6	1.02	0.16
1¼"	3.94	0.67	0.69	1.57	0.71	5.51	0.31	1.57	5.31	3.94	7.09	M8	1.77	0.16
1½"	6.30	0.67	0.69	1.97	0.71	5.91	0.31	1.57	6.65	4.33	7.87	M8	1.77	0.16
2"	6.30	0.71	0.75	2.48	0.71	6.50	0.35	1.57	6.89	4.92	9.06	M8	1.77	0.16
2½"	7.48	0.71	0.75	2.95	0.71	7.28	0.39	2.13	9.65	5.71	11.42	M12	3.94	0.16
3"	7.48	0.79	0.83	3.54	0.71	7.87	0.43	2.13	9.65	6.30	12.20	M12	3.94	0.31
4"	9.45	0.79	0.87	4.33	0.71	8.66	0.47	2.52	11.22	7.09	13.78	M10	3.94	0.31

# DVS Series

## Parts Listing

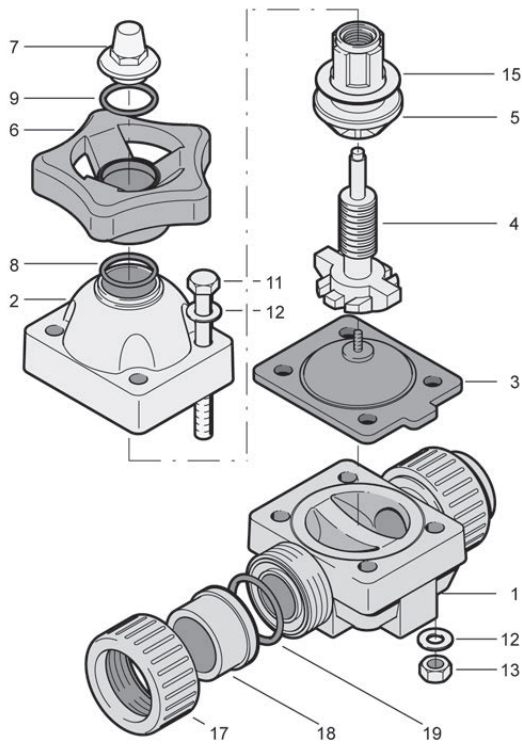

½" to 2"  
Socket / Butt Fusion

Number	Description	Qty
1	Valve Body	1
2	Bonnet	1
3	Diaphragm	1
4	Spindle	1
5	Spindle Nut	1
6	Handwheel	1
7	Indicator Cap	1
8	O-ring	1
9	O-ring	1
11	Hex Bolt	4
12	Washer	8
13	Hex Bolt	4
15	Bearing Ring	1
17	Union Nut	1
18	Union End	1
19	O-ring	1

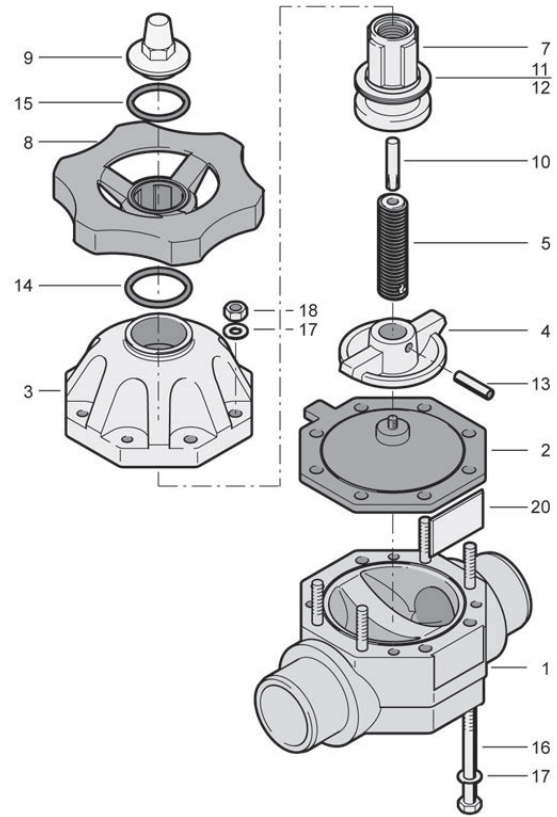

2½" to 4"  
Butt Fusion

Number	Description	Qty
1	Valve Body	1
2	Bonnet	1
3	Diaphragm	1
4	Compressor	1
5	Spindle	1
7	Spindle Nut	1
8	Handwheel	1
9	Indicator Cap	1
10	Indicator Pin	1
11	Axial Bearing	1
12	Axial Bearing Disc	1
13	O-ring	1
14	O-ring	1
15	Hex Bolt	4
16	Washer	8 or 12
18	Hex Bolt	4 or 8
20	Name Plate	1